



**AMERI-CAN**  
**MACHINERY LTD.**

# **C4 and C4 PLUS**

---



## **USER AND MAINTANANCE MANUAL**

2650 MEADOWVALE BLVD., UNIT 5, MISSISSAUGA, ONTARIO, CANADA, L5N 6M5  
PHONE (905)-542-2055, FAX (905)-542-2261, Toll Free# 1-877-829-5219  
WEB SITE: [www.ameri-can.ca](http://www.ameri-can.ca) E-MAIL: [sales@ameri-can.ca](mailto:sales@ameri-can.ca)

## 1 TO OUR CUSTOMERS

### 1.1 CONGRATULATIONS FOR YOUR CHOICE

Your machine has been built with the most advanced technological system; this with the design strength is prerogative of precision and reliability.

The correct use and the adequate maintenance will maintain unchanged its functional and safety features, ensuring high-level performances.



**The customer has the responsibility to make sure that if this document undergoes changes by the Manufacturer, only the updated versions of the Manual are actually present at the point of use.**



**THE OFFICIAL LANGUAGE CHOSEN BY THE MANUFACTURER IS THE ITALIAN LANGUAGE**

**No responsibility is assumed for translations in other languages that do not conform to the original meaning.**

## 1.2 EXPLANATION

This manual is divided in three different sections:

- Commissioning: must be carried only by service and maintenance staff, after a careful reading of this manual.
- Use: must be carried out only by people who received adequate instructions by the service staff or a local representative.
- Maintenance: must be carried out only by the service and maintenance staff, adequately learned by the technicians or a local representative.

Damages due to the failure of following what written in the manual, or procedure conflicting with it, CANNOT BE ASCRIBED TO US.

Some maintenance and reparation interventions can prejudice the functional and/or safety features: these operations are deliberately omitted in this manual. The operations of maintenance, calibration, regulation, reparation that are not contemplated in this manual **must be carried out** by authorized personnel, or by a local representative.



**The term QUALIFIED PERSONNEL covers personnel who as a result of education and professional experience has been expressly authorized to perform the installation, use and maintenance of the machine.**

## **2.2.1 TO WHOM IT IS ADDRESSED**

This manual is addressed to the user, to the leaders in charge of the shift, installation, operation, monitoring, maintenance and final dismantling of the machine.

## **2.2.2 PURPOSE OF THE MANUAL**

The manual explains the proper use of the equipment, as required by the design assumptions and the specifications. It provides instructions for moving, proper and safe installation, adjustment and use; provides information to address maintenance, it facilitates ordering spare parts.

## **2.2.3 UTILIZATION RESTRICTIONS**

This manual is valid for the machine code into it expressly referred; the information cannot be applied to other models of different series. All necessary information will be obtained from this manual without acquiring data from similar manuals of similar equipment or of other manufacturers.

# TO OUR CUSTOMERS

## 2.2.4 SAFETY SIGNS

In order to draw attention in the manual some pictograms appear that will be divided as follows:



**PROHIBITION**



**CAUTION**



**INFORMATION**



**RESERVED TO  
QUALIFIED PERSONELL**

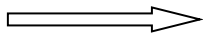

### **DETAILS INDICATIONS**

<b>WARNING</b>	Regarding features or technical requirements that, usually, must precede the operation.
<b>ATTENTION</b>	Regarding all the working and maintenance phases, must be observed scrupulously to avoid damages to person or to the machine.
<b>DANGER</b>	Usually used with the term that define the kind of the injury: ex. "Crashing danger"
<b>DANGEROUS AREA</b>	Define an area inside or near the machine where a person is exposed to risk.





Drawings, tables and pictures are not numbered singly.

Wire diagrams and layouts are not numbered with separately.



## 2.2.5 SAFETY SIGNS

The signs should be applied in areas where they are easily visible and legible by anyone who approaches and at a point such that the person can react promptly to take the necessary action to avoid the danger. The rule provides that the safety pictograms are regularly checked and cleaned to ensure good readability at a safe distance.

### SIGNS RELATED TO HAZARDS

SIGN	DESCRIPTION
	<b>Chips projection</b>
	<b>Electrical power</b>
	<b>Danger of crushing hands</b>
	<b>Moving mechanical parts</b>

### SIGNS RELATED TO PROHIBITIONS

SIGN	DESCRIPTION
	<b>Do not remove the safety devices</b>
	<b>Prohibited to repair / grease during motion</b>

## SIGNS RELATED TO OBLIGATIONS

SIGN	DESCRIPTION
	<b>Must wear safety glasses.</b>
	<b>Must wear protective gloves.</b>
	<b>Must wear ear protectors</b>
	<b>It is compulsory to wear protective shoes</b>

### 2.2.6 COMPLIANCE WITH THE LAWS

Together with the rules of this manual the laws specific to the prevention of accidents at work must be respected by the customer.

### 2.2.7 MANUAL CONSERVATION

The manual is considered an integral part of the machine and must be kept in good condition until its final disposal. The manual should be kept in a protected, dry place, away from direct sunlight and should always be available and available for consultation in the workplace.

### 2.2.8 HOW TO ASK ANOTHER COPY OF THE MANUAL

In case of damage to the original, a copy can be requested at the expense of the applicant directly to the manufacturer.

## 2.2.9 INFORMATIONS TO THE USER

1. This manual reflects the state of the art at the time of commercialization of the machine.
2. The manufacturer reserves the right to change products and manuals, without any obligation to update preceding products or manuals.
3. The characteristics of the materials can be changed at any time in the light of technological change without notice.
4. On the sale of the unit please inform the manufacturer, the address of the new owner so the transmission of any additions to the manual.
5. For further information or clarification you can contact the Service Department

**The manufacturer is relieved from any possible liability in the event that the machine will be:**

- 1) Used improperly
- 2) Used by not qualified personell
- 3) Used against what written in the present manual
- 4) Used againt the current Laws and Legislation
- 5) Used with a wrong main power supply
- 6) Used exceeding its performance limits
- 7) Subject to excessive mechanical stresses

**The user is committed to ensure that:**

- 1) All work related to transportation, connection, operation, maintenance and repairs are performed by qualified personnel
- 2) Qualified means (according to IEC 364) personnel that for training, education, experience, as knowledge of standards, legislation, safety measures and conditions of use and service, is able to carry out any necessary steps avoiding any possible danger and / or damage.
- 3) These people have all the instructions and information necessary, including any local legislation, and that they adhere to these to carry out any operation
- 4) Any operation on machines and equipment also indirectly is forbidden to unqualified personnel



## TO OUR CUSTOMERS

5) Must be repeated during installation, with additional security measures, any local or special requirements and / or at least all of the conditions of prevention not acquitted

### 2.2.10 MARKING DATA AND DELIVERY CHECKS

Make sure that the equipment for signs of damage and that the delivery is complete. In case of damage contact the insurance company or the supplier. If the supply does not conform to the order, contact the supplier immediately. Each item of equipment is a plate.

### 2.2.11 IDENTIFICATION PLATE AND CE MARKING

Each machine is identified by a CE plate on which are reported in indelible way the reference data of the same. The position of the plate on the machine can vary from machine to machine.

For any communication with the manufacturer or service always refer to this reference.

<b>TIPO / TYPE</b>	<input type="text"/>
<b>MATRICOLA / SERIAL - NUMBER</b>	<input type="text"/>
<b>DATA / DATE</b>	<input type="text"/>

___ kW	___ V	___ Hz
___ PH+PE	In ___ A	Icc 10 kA
___ Kg		

MAIN DOCUMENT

  
MADE IN ITALY

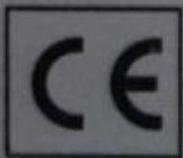
## 2.2.12 DECLARATIONS

The machine is made in accordance with the relevant and applicable EU directives at the time of its release on the market.

### **DICHIARAZIONE “CE” DI CONFORMITÀ MACCHINE**

Si dichiara che la macchina indicata in calce è conforme alle seguenti Direttive Europee:

- Direttiva Sicurezza Macchine (2006/42/CE);
- Direttiva Bassa Tensione (2006/95/CEE e successiva modifica: 93/68/CEE);
- Direttiva Compatibilità Elettromagnetica (2004/108/CEE e successive modifiche: 92/31/CEE e 93/68/CEE).
- Direttiva macchine CEE 2006/42/CE.

### **PROHIBITION OF COMMISSIONING**

*The machine cannot be put into service, after constructive changes or additions of other components not covered by the ordinary and extraordinary maintenance without having again to comply with the requirements of the Directive 2006/42 / EC and of the applicable EC Directives.*

**TO OUR CUSTOMERS**



# TO OUR CUSTOMERS

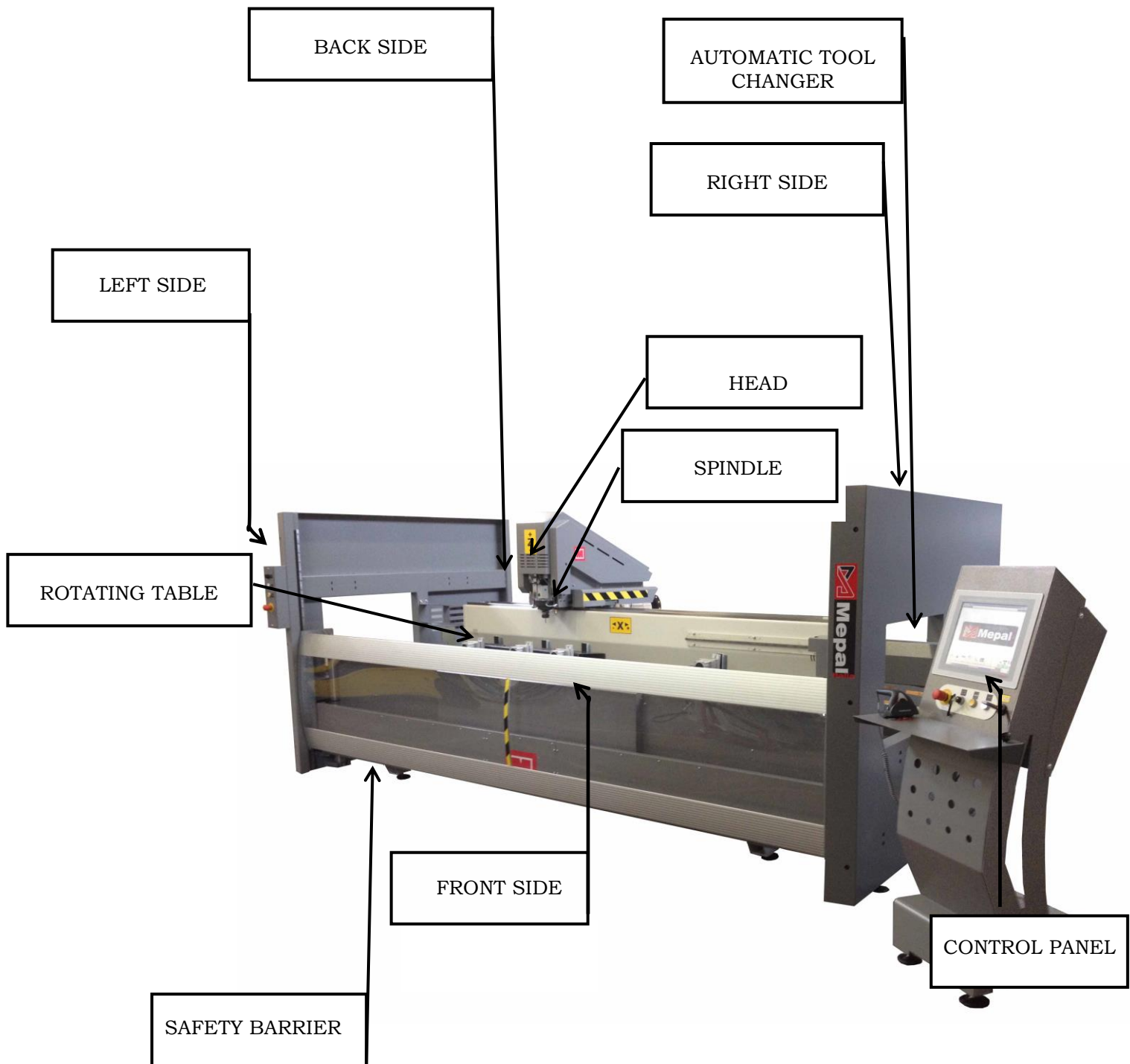

## 2.3

## SAFETY REGULATIONS

Under the European Directive 89/392/EEC, as amended by Directives 91/368/EEC, 93/44/EC and 93/68/EC, the machine has been constructed in full accordance of the following European safety

- EN 292 part 1 and part 2: Machinery safety
- EN 294: safety distances to prevent danger zones being reached with the upper limbs.
- EN 349: clearances to prevent crushing of parts of the body.
- EN 547 part 1 and part 2: Safety of machinery.
- UNI 8459 Ergonomics of work systems.
- EN 418 Safety of machinery. Emergency stop equipment, functional aspects. Design Principles.
- EN 953 Safety of machinery. General requirements for the design and construction of guards (fixed, amovable)
- EN 1037 Safety of machinery. Isolation and energy dissipation. Prevention of unexpected start-up.
- EN 954-1 Safety of machinery. Safety related parts of control system - Part 1: General principles for design.
- EN 1088 Safety of machinery. Interlocking device with and without guard locking. General principles and provision for design.
- EN 983 Safety requirements for fluid power system and components. Pneumatics.
- UNI 6861 Oleo hydraulic and pneumatic systems. Graphic signs.
- UNI 4598 Tool machines. Graphic signs.
- UNI ISO 841 Numerical control of machines. Axis and motion naming.
- UNI 7543 part 1 Colors and safety signs. General requirements.
- UNI 7543 part 3 Colors and safety signs. Warnings.
- NF EN 12417 + A2 April 2009

## 2.4 MACHINE PACKAGING

The standard packaging of the machine provides:

- Machine accessories in a carton.
- Keys, this manual and possible other documents inside the electric cabinet.

The machine, with all the accessories, is shrink wrapped.

If requested, the machine can be packed in a wooden box.

## 3 PREPARATION

### 3.2 LIFT AND HANDLING

The lift of the machine for the transport, loading and unloading, is contemplated for the use of a forklift. For this purpose on the frontal side of the machine are placed appropriate locations for the forks of the forklift.

The machine rests on 4/8 adjustable feet, that allow the passing of the forklift.

Before starting with the lift operations, it is necessary to be sure that the forklift capacity is greater than the machine weight and the forks long enough to support correctly its weight.

In the following table the weights of the various models are written:

<b>C4</b>	
Length (mm)	5800
Weight (Kg)	2000

**Forks min. length: 1.000 mm**

**Forks min. distance: 800 mm**

## 3.3 ADVICES FOR THE WORKING PLACE

Suitable choice of the place of work of the machine is very important in order to obtain a good quality of production and proper functioning of the machine itself.

The choice of the workplace must take into account, the overall dimensions of the machine and the movement of the material to be processed, both incoming and outgoing. The positioning to walls, or overall fixed dimensions in general, should be made, considering that it must be possible an easy access to all sides of the machine for normal operation of cleaning or maintenance.

The machine does not need foundations; however, it is appropriate that the bearing surface is sufficiently rigid and able to withstand localized pressures (in correspondence with the support feet) higher than 5 kg/cm<sup>2</sup> (corresponding to a concentrated load of 400 kg). If not it is necessary to increase bearing surface of the feet by means of steel plates, of round or square shape, with a thickness of at least 1/200 of the surface.

(Example: plate 200x200 mm, minimum thickness 20 mm ⇒ contact pressure 1 Kg/cm<sup>2</sup>).

### **GENERAL SAFETY WARNINGS**

***The machinery has been designed to be used from only one operator that must position himself in front of the machine where is possible to reach easily all machine commands including the emergency commands. Moreover the operator must have the complete control of the work cycle.***

*The operator must immediately stop the operations in progress if for every reason the blade does not go down in the rest position or if any anomaly is noted.*

*The operator must stop the operations in progress if other people approach the machine.*

### **LIGHTING**

*Must be provided adequate lighting, natural or artificial in accordance with ISO 8995-89 on lighting at the workplace.*

### **GROUNDUNG SYSTEM**

*Must be performed at CEI 64-8.*

### **INTENDED USE**

*The cutting machine is adequate to cut light aluminium profiles using appropriate blades.*

### **NOISINESS**

*average sound vacuum pressure: 71,0 dba*

*average sound pressure at work: 86,4 dba*

*vacuum sound pressure: 87,0 dbwa*

*sound pressure at work: 101,0 dbwa*

*vacuum lop user place: 81,0 dba*

*lop user place at work: 97,0 dba*

*maximum sound pressure level in the user place 119,0db*

***It is advised the use of individual safety protection devices against noise in the case of prolonged use of the machine.***



# PREPARATION

## **PACKING**

*The machine is supplied with a shrink-wrapping.*

## **LEVELLING**

*The machine has to be levelled transversely and longitudinally.*

## **OPERATING TEMPERATURE**

*From 10 °C to 40 °C.*

## **CLEANING**

The machine should be cleaned with detergents, non-acids or non-aggressive to paints, we recommend specific industrial products.

Do not use acids, gasoline, paint thinner, turpentine or petroleum.

Use gloves and suitable clothing.

## **SAFETY DEVICES**

*Pressure switch of minimum pressure, if the pressure is not sufficient the blade will not start.*

*Valve of low and high pressure: when closing the clamps the pressure is about 2.5 bar only when pressing the two buttons and the work cycle begins then takes over a pressure of about 7 bar, to prevent crushing even if slight of the hands.*

*One way valves on the clamps: if the pressure is missing the clamps will remain closed and the profile locked.*

*Command cycle with two hands: you have to press both buttons simultaneously to start the cutting phase, with two-hand safety valve. The working cycle is interrupted releasing one of the two buttons.*

*Fixed protective casing.*

*Blade casing with protective strips of plastic against-intrusion. Replace them immediately if they get weared.*

*At the rear of the turntable were applied two mechanical stops that prevent direct the plane in positions that may cause the meeting of the blade with the iron structure.*

## **RESIDUAL RISKS**

*Despite the barriers and safety devices, the machine has the residual risks caused by improper use of the machine or unpredictable situations. These risks are reported with safety signs.*

*Please be aware that in the electric panel even with main switch off there is electricity.*

*The pneumatic circuit even if disconnected remains under pressure. If in case of malfunction the blade does not come down, do not put your hands near to the work area until the blade is fully back and stopped. The operator must use precautions and individual devices according to the current legislation: glasses, gloves, headsets and all that is necessary according to the residual risk analysis in the workplace.*

*The operator must necessarily turn off and lock the main switch and unplug the machine from the air by venting the pressure from the air system if:*

*-must clean or remove protective casing to make any type of operations, he must wait the time required for the stopping of the blades and their return to the rest position.*

*-to carry out maintenance work in the machine working areas.*

*-to carry on whatever operation in correspondence of the machine blade.*

*-to carry on whatever adjustment operation on the machine.*

*The machine is equipped with safety devices: it is prohibited any alteration, modification or partial removal of these devices.*

*Check at the beginning of each work shift their presence and efficiency, otherwise alert immediately the responsible person.*

*The use of compressed air to clean or to blow up the chips must be carried on only with adequate eyes protection (glass).*

*The electrical equipments can cause accidents.*

# PREPARATION

The work areas should not be approached with the hands, being present in the machine components with sharp or high pressures and movements unwary can cause injury.

For every reason do not let unauthorized personnel to operate on the machine.

Do not wear jewels, unfastened, loose-fitting and dangling clothes that could catch in the moving parts.

It is advised the use of suitable clothing, safety shoes, safety glass, face masks.

Do not start the machine if there is any anomaly.

The working area must be always clean and dry.

During the assembly and disassembly of casing or other parts, do not align any holes with your fingers but with appropriate tools as there may be danger of crushing.

It is advised the use of suitable clothing, safety shoes, safety glass, face masks.

Do not start the machine if there is any anomaly.

During the assembly and disassembly of casing or other parts, do not align any holes with your fingers but with appropriate tools as there may be danger of crushing.

The safe area is the area indicated as **operator area**, in the rear area indicated as **maintenance area** must not stay anyone, particularly if you do not equip the machine with a chips and fumes extractor, as there is a filler pipe from which chips and fumes can be expelled. It is therefore necessary to provide optionally a bag or a suitable container for the collection of any chips.

It is forbidden to insert objects, tools or body parts inside the filler pipe for the suction of the chips: this action can cause damage to people and/or property.

The lateral area indicated as **load area** must be used only for the eventual loading and unloading of profiles, only when the machine is off.

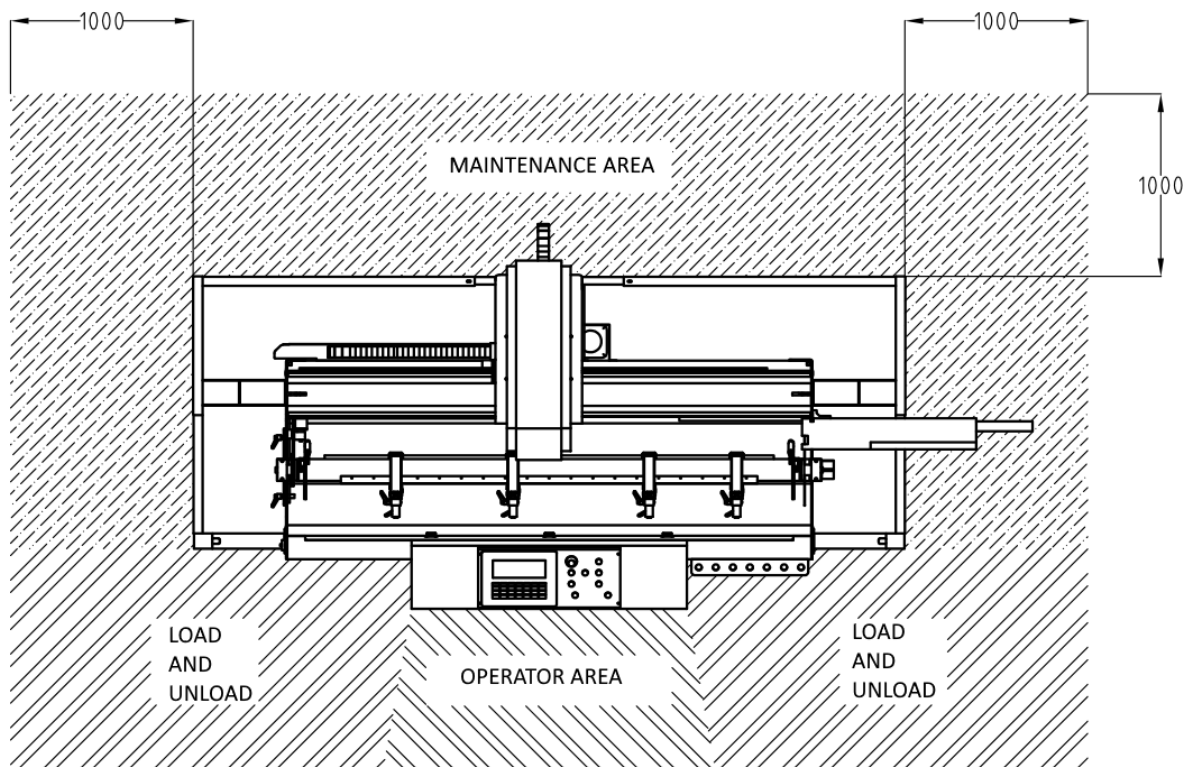

# PREPARATION

## 3.3.1 MORE ADVISES FOR THE WORKING PLACE:

- Absence of vibrations.
- Uniform heating or cooling of the machine to avoid localized deformation: it is not recommended, therefore, the installation of the machine in a place where sunlight or air currents, cold or hot, from one side only could invest it.
- Absence of dust in the environment.
- Operating temperature as constant as possible and in any event not less than 10°C (50° F) and not more than 35° C (95° F).
- Humidity of air not exceeding 80%
- Proper natural or artificial lighting.



**The machine is not suitable for use in areas with explosive atmosphere, corrosive, with excessive amount of dust.**

## **3.4 SEPARATED PARTS ASSEMBLY**

### **3.3.1 UNPACKING**

Place the machine following the instructions in the previous paragraph.

Without the polyethylene cover, cut the straps that secure the boxes of accessories to the guide of the machine.

### **3.4.1 CONSOLLE**

If the console is disassembled, place the console nearby the machine and connect the connector to the electric cabinet. Turn on the machine and check carefully the machine functioning.

### **3.3.3 SCREENS**

After placing the machine, we recommend the removal of protective films scratchproof only when you finish these operations.

The cleaning of the same should be done only with water and soap or cleaning products for domestic glass.

## 3.5 CONNECCTION TO ELECTRIC POWER

### 3.4.1 PNEUMATIC PARTS

The pneumatic supply of the machine is provided on the right side. The connection must be made at the entrance of the general shut-off valve, by means of rigid or flexible tubes such that, in the quantity required, allowing a pressure of at least 7 bar to the machine.

The machine is equipped with a filter with condensation separator and does not need air totally dehydrated, however, it is appropriate that the plant is made in order to limit the direct input of water and impurities.

If the connection between the machine and the distribution system of compressed air is carried out with flexible tubing it is appropriate to include an isolation valve also on the side of connection to a rigid plant.

**ATTENTION: CRUSHING DANGER.** When starting the pneumatic supply some unexpected movements will take place, for example, the lifting of protective screens and turning heads: before opening the compressed air supply, make sure there are not people in the immediate vicinity of the machine.



The machine control system pressure is made with the pressure regulator control knob: clockwise to increase and counterclockwise to decrease. The lowering of pressure takes place through the adjustment relieving of the regulator and, therefore, it is advisable to flow over the predetermined value, wait a few seconds for the stabilization and then go up slowly.

The adjustment the pneumatic system lubrication can be carried out on the lubricator on the side of the regulator: the operation must be done after completing all the tasks in this chapter. Dose adjustment for the fall of a drop of oil (transparent upper cylinder) every 4-6 complete cycles.

# PREPARATION

## 3.4.2 ELECTRIC PARTS

The electrical supply of the machine is provided on the left side. The machine comes with a power cable 3 poles + ground (4x2.5 mm<sup>2</sup>) of 5 meters, with no plug.

**Under the current regulations, the connection to the electrical line must be performed by qualified personnel.**

The machine, unless the customer's particular requirements, comes ready to run on 400 volts - 50 Hz three-phase (400 V 3PH+PE), or if requested 220 V – 60 Hz three-phase (220 V 3PH+PE).



**ATTENTION:** if a chips belt conveyor is installed on the machine, once the connection to the electrical line and a suitable grounding are made it is necessary to verify the correct motor rotation: looking at the machine from the front side, the chips belt conveyor must turn clockwise.

## **3.6 SAFETY PROTECTIONS**

The machine complies with European standards of safety prevention and protection of the operator. It is however necessary that access to certain areas of the machine, in particular the rear side, is protected against accidental intrusion by third parties, during normal operation. The access should be allowed and easy for cleaning and maintenance, when the machine is stopped, by the assigned personnel.

## 3.7 PRELIMINARY CLEANING

The machine, before being packed for shipment, is sprayed with protective antioxidant chemicals that must be removed before starting the machine.

Before proceeding make sure the switch is turned off.

Cleaning can be done with common detergents, non-acidic or non-aggressive to the paint: we recommend the specific products (according to the law) of industrial use or, without those, the normal household detergents. Use gloves and clothing suitable for the use of products used for cleaning.

Particular attention should be given to the longitudinal slide rails, which must also be cleaned under the moving head, moving it manually. After cleaning and complete removal of all traces of protective and detergents, grease them lightly wiping from top to bottom with a cloth soaked with oil. Move the mobile head repeatedly checking that gaskets do not tend to get stuck or topple over.

Do not use acids, gasoline or petroleum derivatives, solvents, trichloroethylene and similar.

The cleaning of protective screens, control panel, pressure gauge and, in general, of all the plastic parts must be made only with water and soap or inert detergent.



## 3.8

### LEVELING

The machine sits on the floor with adjustable feet (6 or 8, depending on the length of the basement) which allow the horizontal leveling of that. The leveling must not, necessarily, be made with sophisticated tools not being necessary to make it perfectly horizontal, but rather a good support that does not lead to torsional stresses to the basement. It is sufficient a level, at least 50 cm long and in good condition.

# GENERAL DESCRIPTION

## 4 GENERAL DESCRIPTION

### 4.2 MACHINE



## 4.3 MACHINE INTRODUCTION

This machining center is designed for machining aluminum and light-steel profiles for the construction of fixtures, for building construction and architecture, or similar where it is necessary for high productivity, ease of use reliability, robustness and limited maintenance.

The main features of the machine, predetermined at the design stage and made in the construction phase, are the following

- High dimensional and geometric stability.
- Low maintenance costs.
- Ergonomics work.
- Ease of maintenance.
- Full access to all its components.
- High machining capacity.
- Easy to learn.
- High accuracy.
- Adaptability to the needs of the customer and operator

## 4.4

### WORKING AREA

The working area of the machining center has been designed to achieve the following characteristics:

- Wide visibility of the whole machine and of hazardous areas for third persons during the processing phases.
- Fall of the waste inside the basement, removable tanks for collection.
- Free fall of the chips, or, by external vacuum cleaners, conveying to the intake manifold.
- Good view of the working zones, with maximum security protection from flying chips, scraps and / or fragments

## 4.5 WARNINGS FOR THE OPERATOR

- The machine is designed for use by a single operator.
- In case of accidental approach by third persons, and in presence of potential source of danger, stop ongoing operations through the emergency stop buttons.
- The operator must ensure that the refrigerant liquid which is introduced using the tanks is non-toxic and UNDER THE LAW.

### **The operator has the duty to turn off the main switch before:**

- Move away from the machine.
- Proceed with cleaning and / or removal of the waste-holding tanks.
- Make adjustments involving the opening of fixed guards.
- Intrude, in case of maintenance, in the areas of motion of the machine.

### **The operator has the duty of turning on the emergency switch before:**

- Record the position of clamps.
- Perform any operation in correspondence with the heads.
- Place the stops for special angles.



**The use of products / materials other than those specified by the manufacturer, which can cause damage and danger to the operator and / or those close to the machine, is considered incorrect and improper.**

## RESIDUAL RISKS

1. In any case, the operator must not carry out operations near the without making sure that the spindle itself is in still position and stopped;
2. In case of failure, the protection could stay open while working: stop the machine and call for service. Always avoid approaching the tool without first making sure that it has stopped.
3. During the movement of the mobile carriage, the operator must carefully check that nobody is in the working area or around the machine.
4. It is forbidden to remove the safety devices.

## GENERAL DESCRIPTION

The machine has low noise levels. Where the processing, because of the very nature of the material being processed, will cause discomfort to the operator, the operator, in the absence of barriers or other noise reduction systems, must wear the soundproof headphones.

The machine is equipped with devices set for the protection and safety of the operator. It is prohibited the tampering, removal or modification even partial of such devices and protection.

### **Acoustic emission values:**

- The weighted level A of sound pressure in the workplace is 88.9 dB;
- The maximum weighted value C of instantaneous sound pressure in the workplace is 108.8 dB;
- The weighted sound power level A emitted by the machine is 104.8 dB.

After installing the machinery, the employer will be required to make a risk assessment of the noisiness as required by the legislation

Tool: HM or HSS milling tool.

## 4.6

### WARNINGS FOR THE MAINTENANCE

#### **The maintenance staff of the machine must:**

- Perform the proper operations ensuring that the movements of the machine cannot be a source of danger to third persons. It is necessary to immediately stop the ongoing operations whenever a third person is approaching parts moving or whose movement can be done by automated cycle.
- Verify that the liquid refrigerant which is introduced using the tanks is non-toxic and UNDER THE LAW.
- Turn off the main switch before:
  - Get away from the machine.
  - Remove casing and/or fixed protections.
  - Intrude, in any case, in the areas of motion of the machine.
- Perform the maintenance operations as stated in the relevant chapter.

#### **The maintenance staff must not:**

- Perform any modifications.
- Tamper, remove or modify even partially devices and safety guards.

## 4.7

### MACHINE'S MOVEMENTS

The main movements of the machine are:

- Opening / closing clamps
- Opening / closing protection screens
- Head movements (X, Y and Z axis)
- Opening / closing automatic tool changer
- Power on / off spindle motor



# GENERAL DESCRIPTION

## 4.8.1 OPENING/CLOSING CLAMPS

The locking clamps installed on the machine are constituted by pneumatic cylinders with simple operation. The cylinders are provided with check valve for safety at the cutting of the supply tube. The machine is equipped with four units of horizontal clamps, each mounted on an arm which allows the movement axial (approaching/moving away from the work piece) and the transverse movement of approaching / moving away from the bearing surface. The horizontal arm of the clamp is, in turn, mounted on a support that can be translated longitudinally.

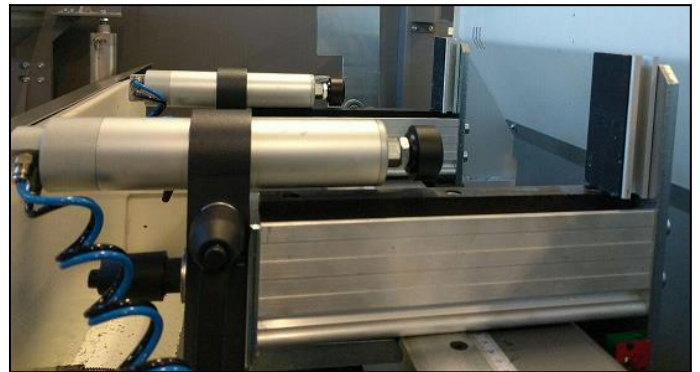

The motion of the clamps is controlled by the console through the specific yellow button (A) and (B) at low pressure.



A

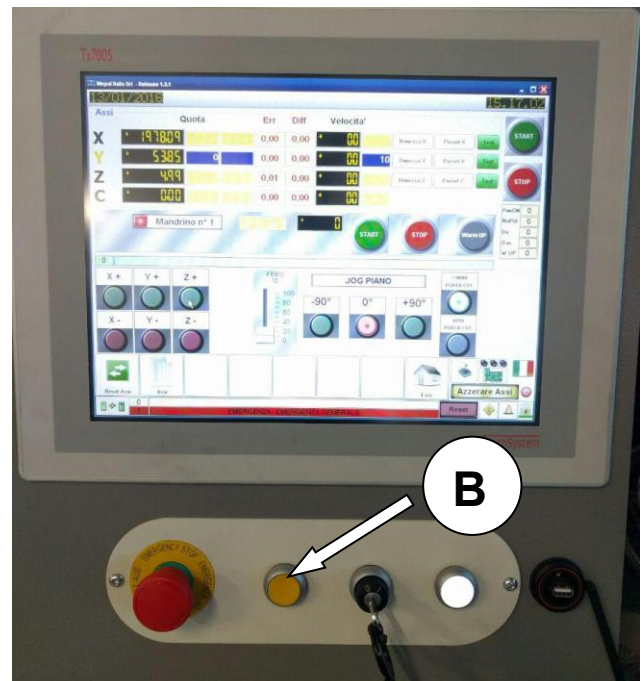

B

While the clamps are closing the cylinders are working at low pressure (about 1-1.5 bar) to keep the operator safe if the hands are pressed between the clamp and the profile or between the profile and the surface plate. This is to avoid the **crushing danger**. When the cycle has been started and the operator is out of the dangerous area the pressure switches to the high pressure, reaching the maximum force of clamping.

# GENERAL DESCRIPTION

## 4.8.2 OPENING/CLOSING PROTECTION SCREEN

If the machine is equipped with a full cabin (picture below), a frontal protection screen (A) will divide the working area from the operator area.

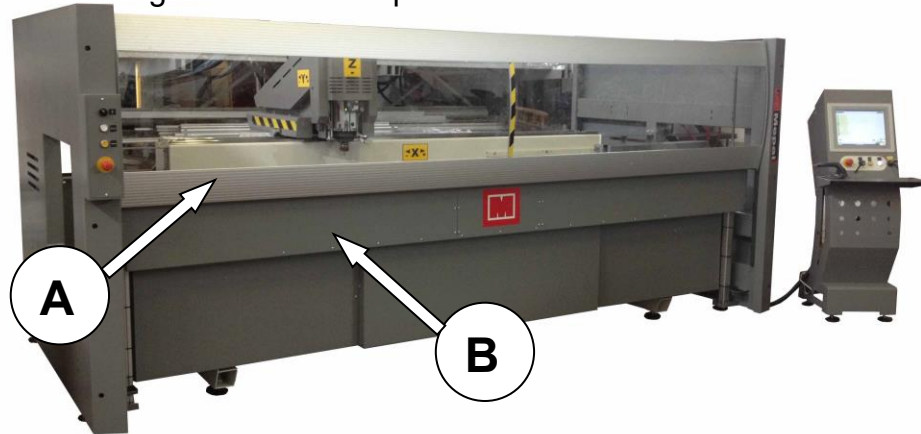

The protection screen moves due to pneumatic cylinders, pressing the 2 yellow buttons the protection screen will automatically close. It is necessary to close the protection screen for the automatic movements of the axis and of the automatic tool changer.



To open the protection screen, press the 2 yellow buttons.

	<b>Danger of crushing hands</b>
	<b>Moving mechanical parts</b>

**Do not put your hands between the protection screen and the machine base-ment.**

# GENERAL DESCRIPTION

## 4.8.3 TOOL LUBRICATION

The refrigeration-lubrication of the tool is provided by a pneumatic nebulizer, adjustable, with pressure reduction (venturi).

Two flexible tubes are connected to the nebulizer: one to the solenoid valve that control the lubrication, the other directly to the tank of the liquid refrigerant.

The adjustment of the flow (micromist) takes place by measuring the air flow and, accordingly to the Venturi effect, it regulates the flow of the liquid.

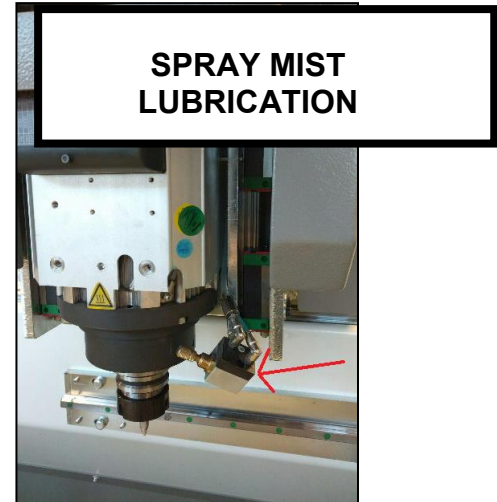

The plastic fuel tank is positioned on the rear side of the machine or, if the machine has the cabin, on the left side.

**WARNING:** the refrigerating fluid must have anti-oxidant features and shouldn't be aggressive towards the paint. We require non-toxic and not irritating products ACCORDING TO THE LAW.

Carefully read the package instructions for preparation - Dilution in water and the maximum duration ant mildew. The product is not recovered from the machine, so the term mold is considered only for the idle periods of the machine.

# GENERAL DESCRIPTION

## 4.8 CONSOLE

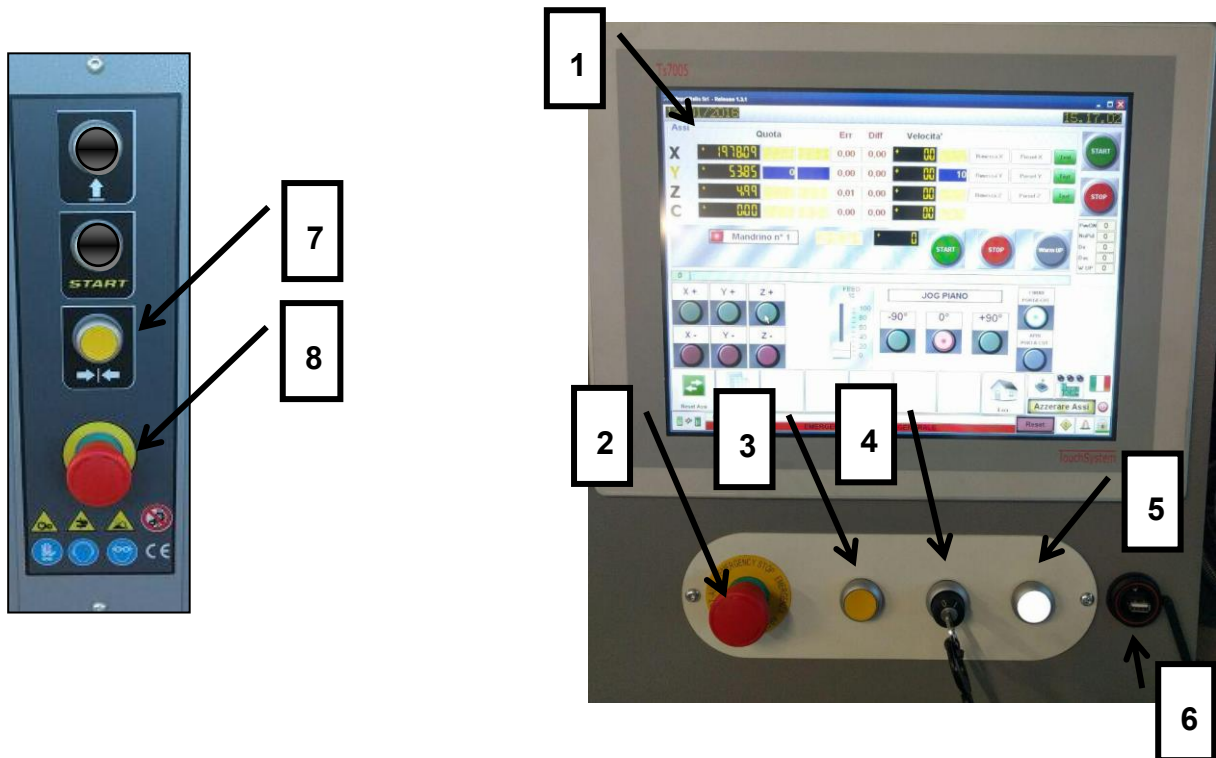

1	TOUCHSCREEN PC
2	EMERGENCY PUSH BUTTON
3	OPEN / CLOSE CLAMPS BUTTON
4	KEY TO TEMPORARERLY DISABLE AXIS LIMIR SWITCHES
5	ENABLING POWER BUTTON
6	USB
7	OPEN / CLOSE CLAMPS BUTTON
8	EMERGENCY PUSH BUTTON

# GENERAL DESCRIPTION

## 4.9 ELECTRIC CABINET

The electrical panel is contained in a separate compartment closed by a door on which the general switch is fixed.



# GENERAL DESCRIPTION

## 4.10 PNEUMATIC PARTS

The pneumatic cabinet is placed in a special compartment on the front side of the machine. The pressure gauge can be seen indicating the air pressure can be seen on the right side.

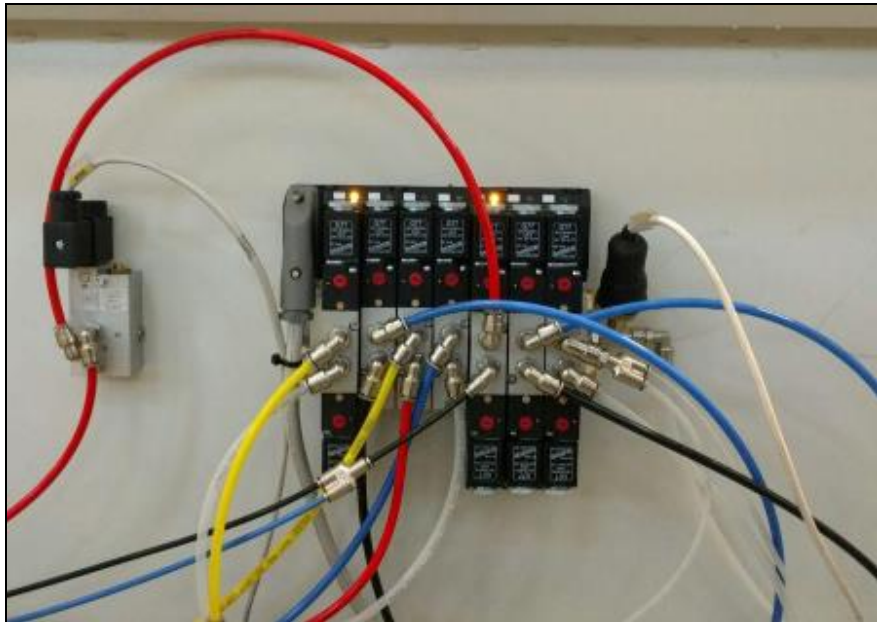



## 5 USE OF THE MACHINE

### 5.1 MEASUREMENT METHOD

#### 5.1.1 HEAD TILTING

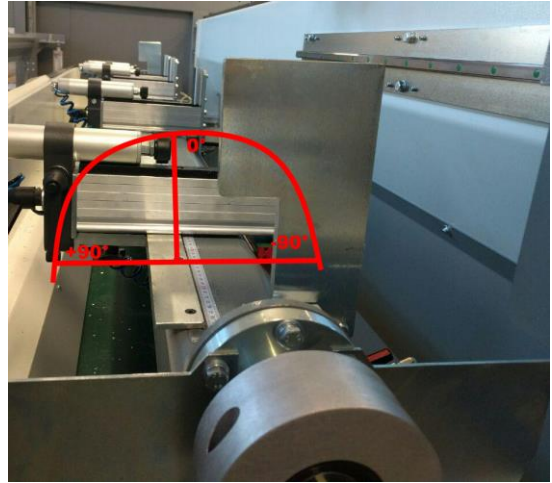

The turning table is composed of a table that can rotate around the horizontal axis between the two sides supports. The turning table can rotate pneumatically in three positions:  $0^\circ$ ,  $+90^\circ$  and  $-90^\circ$ .

The inclination of the table is automatically performed by the control panel installed in the front console.

# USE OF THE MACHINE

## 5.1 WORKING CYCLE

After positioning the profile on the clamps supports, you can start working.

- 1) While the profile is leaning on the support of counter-profiles, or on the clamps supports, you should lock it with the pneumatic clamping. Keeping the profile leaning with just one hand (note that it is not in the workspace between the clamp and the pad) press the open/ close button (1 or 2): the cylinders move forward to press on the profile, the operation takes place at low pressure to avoid risk of crushing the hand.



- 2) Verify that all cylinders of the clamps are resting on the profile, if necessary unlock (by pressing the button 1 or 2), make the necessary registrations and re-lock.
- 3) Verify that the profile is correctly supported.
- 4) When the START button is pushed it will be possible to close the protection screen that close the working area and, after a micro-switch will read the closure of the protection screen, the working cycle will start. The protection screen can be closed pressing the 2 yellow buttons:





## USE OF THE MACHINE

- 5) When the machine completes the working cycle, pressing the 2 yellow buttons will open the protection screen.

**The operation of the Emergency Stop in the machine is executed by pressing the corresponding red button, such action causes the immediate stop all moving and started parts.**



## 6 MAINTENANCE



**WARNING:** only personnel trained for the purpose must perform all maintenance operations.

All operations on the machine should be carried out only after disconnecting the electric power and the pneumatic supply from the machine.

### 6.1 WHAT TO DO IF: . . . .

#### 6.2.1 THE CLAMPS DO NOT OPEN

If at the clamps do not open with the normal command, open the pneumatic cabinet and check the solenoid valve. If the valve is working, check the Input/ Output from the machine software.

#### 6.1.2 THE POWER BUTTON DOES NOT LIGHT



If when pressing the enable button, the button does not turn on and the machine is not working, make sure the switch is plugged in and that the machine is correctly powered.

Check the limiting switches of each axis in the back of the machine base.

Check the contacts and the connection of the emergency switch (red mushroom head pushbutton on the console control).

Check the contacts and connections of the general enable button.

Check the pressure in the network and / or air leaks in the system (at least 6 bar are necessary).

Check operation and wiring of the pressure switch within pneumatic cabinet.

## 6.1.3 THE LUBRICATION SYSTEM DOES NOT WORK

For best efficiency and long life of the spray mist lubrication, before periods of inactivity of the machine and, however, weekly we recommend cleaning of that and of the suction pipe of the liquid.

When the spray mist lubrication of the tool does not work regularly it is necessary to clean the whole circuit with soap diluted in water:

- 1) Remove the tank containing the fluid, empty and wash it.
- 2) Unplug the pipe that from the tank takes the liquid to the nebulizer; blow some compressed air inside it.
- 3) Remove the brass regulator from aluminum body of the nebulizer and wash it thoroughly with the help of a brush.
- 4) Open the body of the nebulizer by unscrewing the two screws: attention inside, between the two parts of the body, there is a steel ball propelled by a spring. Thoroughly clean each piece.
- 5) Reassemble the nebulizer and restore the system.
- 6) Run a few cutting cycles unloaded using only water in the tank.

Empty the water from the system and recover the liquid, filtering out any chips.



**The manufacturer is not responsible for the failure to comply with these recommendations and for each other use deformed or not mentioned in the instructions.**

# MAINTENANCE

## 7.1 COMMON PROBLEMS



PROBLEMS	CAUSE	SOLUTION
MACHINE DOES NOT WORK	Main switch off	Turn on the main switch
THE MACHINE STOPS WHILE WORKING	There is one missing phase	Check the phases
	Thermal overcurrent	Find and remove the cause
THE MACHINING HAS NOT BEEN MADE EFFICIENTLY	Worn tool	Replace the tool
	Not enough lubrication	Check the lubrication
ABNORMAL WEAR OF THE PNEUMATIC PARTS	No pneumatic lubricant in the plant	Refill the lubricant
	Unpurified compressed air	Replace filter
	Water in the plant	Check and fix drain points

## 7.2 ORDINARY MAINTENANCE



**WARNING: All the maintenance operations must be carried out by personnel trained for the purpose.**

**Before performing any maintenance and / or repair, you must isolate the machine from the electric power supply and pneumatic power supply**

### 7.2.1 GENERAL PRESCRIPTIONS

Maintenance includes regularly scheduled inspections, checks and interventions to prevent interruptions and breakdowns, to keep under systematic control the state of machine lubrication and the condition of wearing parts.

Such operations, although simple, must be performed by qualified personnel.

The machine has been designed to minimize routine maintenance, it is the operator judge the state and its suitability for use.

It is recommended, however, to arrest and to intervene with maintenance every time you hear an operation is not optimal, this will always have maximum efficiency.

Always use the necessary safety protection and clothing.

Visually check the conditions of the individual parts of the machine, making sure that there are no defects caused by failures or deformation.

For all maintenance that does not require voltage it is necessary to turn off the machine by sectioning the power from the main switch, locking it, with a suitable padlock, in a position "O" (OFF).

Check and try once a month the proper functioning and operation of the Emergency Stops of the electrical panel.

In case of malfunction entrust the search of the failure only a to service technician or contact the Service Department of the manufacturer of the electrical panel.

Check the grounding according to CEI EN 60207-1 p. 18.2.2 regulation.

# MAINTENANCE

## 7.2.2 SCHEDULED MAINTENANCE PROGRAM

<i>Type of work</i>	<i>Frequency</i>
Cleaning the work area	Daily
Check oil level of the lubricator	Daily
Check emergency stops	Monthly
Lubrication of the carriage bearings of the mobile head	Monthly
Visual inspection of the Pneumatic hoses	Monthly
Pneumatic valves operation checks	Every 6 months (qualified personnel is required)

## 7.3 SERVICE

The network of services is developed nationally and internationally.

For specific problems, please contact the following numbers:



**TEL.: 905-542-2055**

**WARNING:** 

*When you decide not to use this machine, because hopelessly outdated or fails, take the unit out of service by making it inoperative and free of danger. Disconnect the machine from the power supply, disconnect the air ducts, disassemble tools and all parts added. Close them inside enclosures securely closed. Seal the machine in a rugged packaging, and dispose of operating in accordance with current regulations addressing the local organizations responsible for such operations.*

## 7.4 WARRANTY

*The MEPAL ITALY ensures that the machine purchased, before being delivered to the buyer has been tested successfully. The warranty is 12 months and refers to the quality of the material and the lack of construction defects. In case of replacement of defective parts the customer is required to bear the costs of transport and between-packaging.*

*Damage due to tampering, falls, improper use of the machine are not covered.*

*It is recalled that modification interventions made by the user, without the express written consent of the manufacturer will void the warranty and relieves the manufacturer from any liability for damages caused by defective product.*

*This is particularly true when these changes are made on security devices, degrading their effectiveness. The same considerations apply when using non-original spare parts or other than those explicitly specified by the manufacturer as "safety devices".*

*We recommend, therefore, our customers to contact our Customer Service, before making the above work on the machine.*

*Defects clearly and visibly present for the delivery of the product (cosmetic defects on visible parts, cracks, dents, malfunctions, missing parts etc.) Must be immediately reported to the company.*

*The guarantee does not apply if failure to comply with conditions of payment set of purchase. When servicing expenses, related to parts not covered by the warranty and other costs, they will be paid directly to the technician, who will issue a service card.*

*For such expenses will follow an invoice and will cost reported in the current price list.*

# MAINTENANCE

## **AMERI-CAN MACHINERY LTD.**

2650 Meadowvale Blvd, Unit # 5

Mississauga, Ontario, L5N 6M5

TEL: 905-542-2055

Fax: 905-542-2261

Website: [www.ameri-can.ca](http://www.ameri-can.ca)

Email: [service@ameri-can.ca](mailto:service@ameri-can.ca)





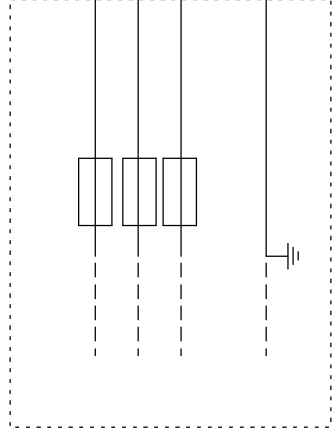

LINEA  
ELECTRICAL LINE

SEZIONE MINIMA (mmq) 2,5

MINIMUM SECTION (mmq) 2,5

LUNGHEZZA MASSIMA (m) 40

MAXIMUM LENGTH (m) 40

CADUTA DI TENSIONE MASSIMA (%) 1

MAXIMUM VOLTAGE DROP (%) 1

DISPOSITIVO DI PROTEZIONE 12 t (A2 sec) 80000

PROTECTION DEVICE 12 t (A2 sec) 80000

Icc<10ka CORRENTE DI LIMITAZIONE

Icc<10ka LIMITATION CURRENT

INTERRUTTORE AUTOMATICO MAGNETO TERMICO  
CODICE TELEMCAMIQUE GV2ME25

INTERMPTOR AUTOMATIC MAGNETO THERMAL  
CODE TELEMCAMIQUE GV2ME25

FUSIBILI TIPO NH25Agg

TYPE FUSES NH25Agg

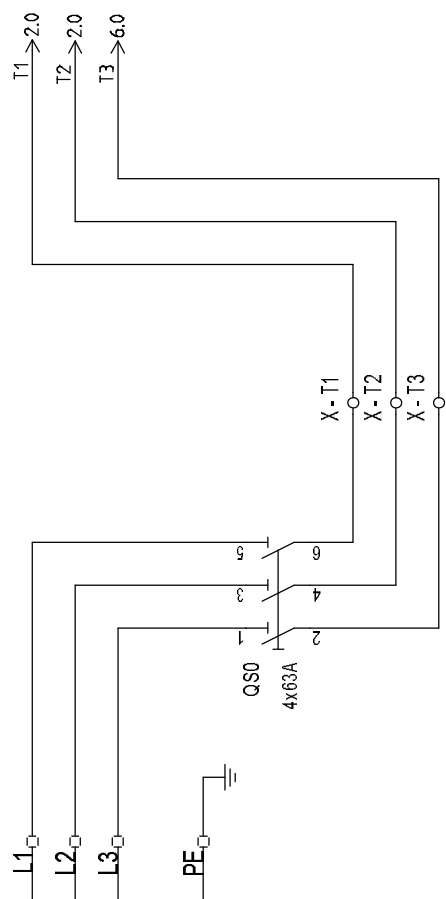

DIMENSIONAMENTO  
DISPOSITIVO DI PROTEZIONE

PROTECTION  
DEVICE DIMENSIONING

DISPOSITIVO DI COLLEGAMENTO  
RETE ELETTRICA MACCHINA

LINK DEVICE  
MACHINE ELECTRICITY GRID

# A CARICO DELL'UTENTE CHARGED TO THE USER

REVISIONE	MODIFICA	PROGETTO - PROJECT: C4 -CSA	FOGLIO 1
DATA	FIRMA	COMMESSA - ORDER: A18-15	DI 27
		CLIENTE - CLIENT:	
		TITOLO - TITLE: Istruzione a carico del cliente	
		DIS - DES: Ellevi product snc	DATA - DATE: 13/02/2018
			< > 2

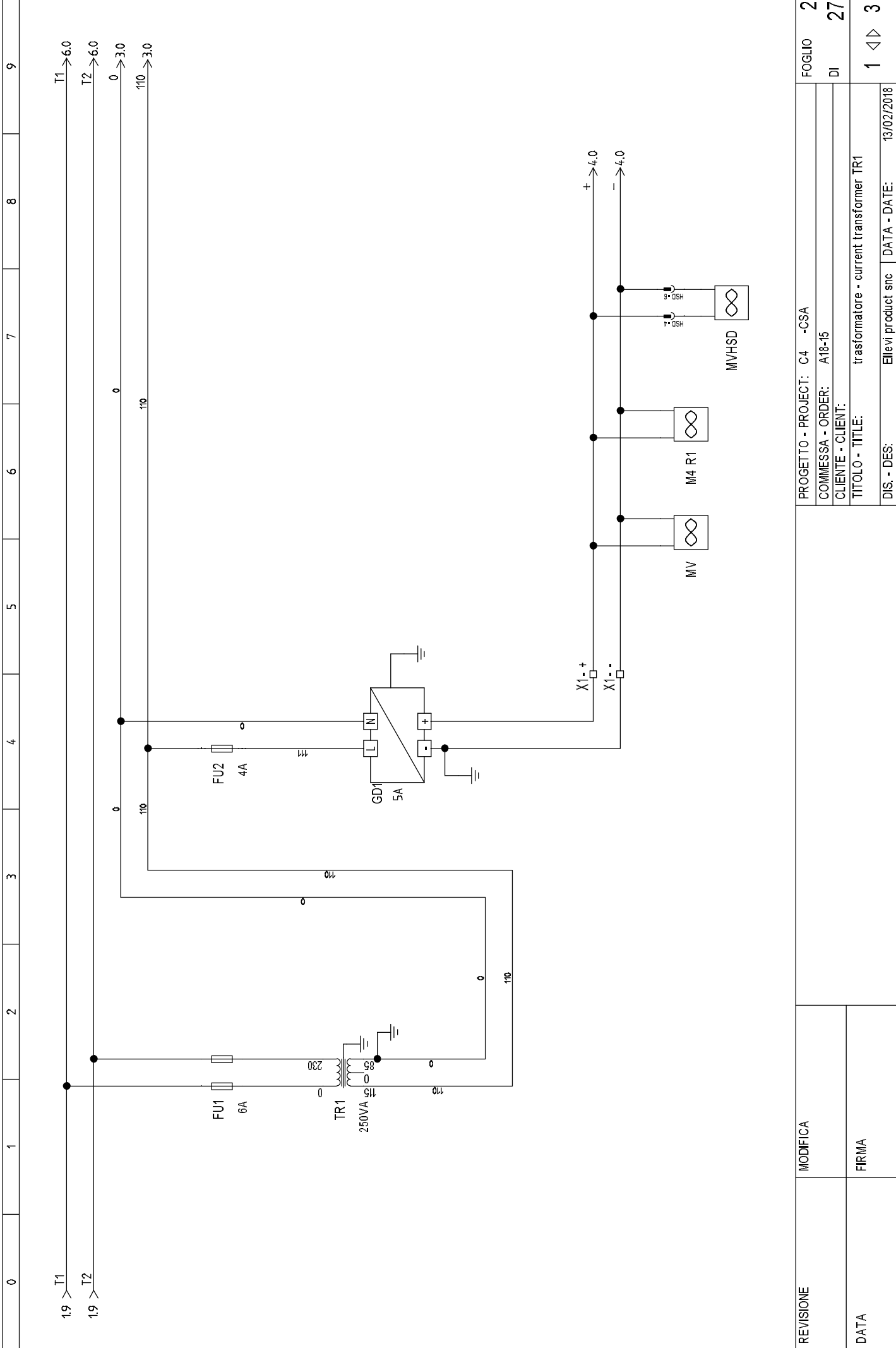

REVISIONE	MODIFICA	PROGETTO - PROJECT: C4 -CSA	FOGLIO	2
DATA	FIRMA	COMMESSA - ORDER: A18-15	DI	27
		CLIENTE - CLIENT: trasformatore - current transformer TR1		
		TITOLO - TITLE: Ellevi product snc		
		DIS - DES: 13/02/2018		
			1 <> 3	

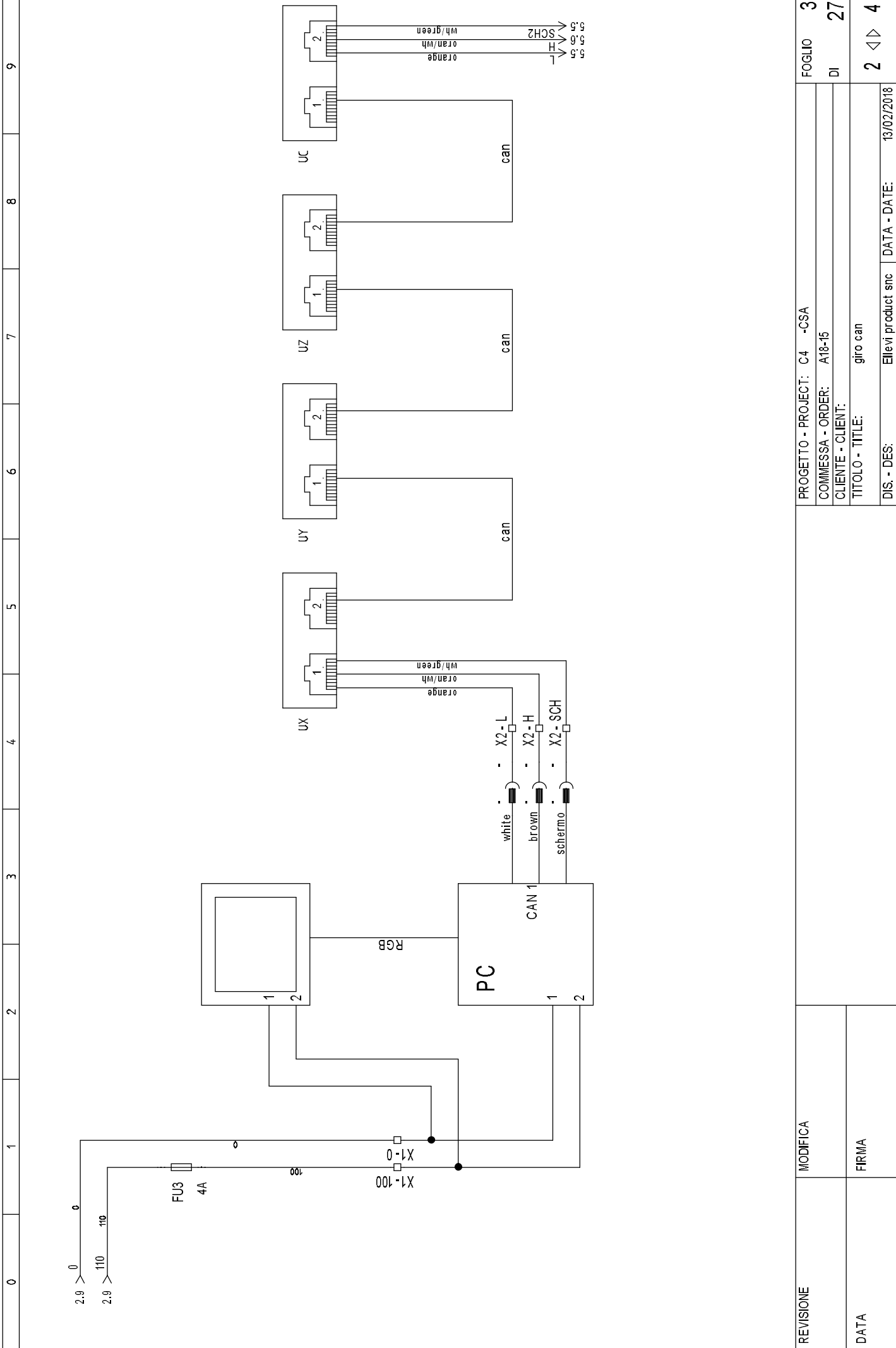

REVISIONE	MODIFICA	PROGETTO - PROJECT: C4 -CSA	FOGLIO 3
DATA	FIRMA	COMMESSA - ORDER: A18-15	DI 27
		CLIENTE - CLIENT: giro can	
		TITOLO - TITLE: giro can	
		DIS. - DES: Ellevi product snc	2 < > 4
		DATA - DATE: 13/02/2018	

CN1

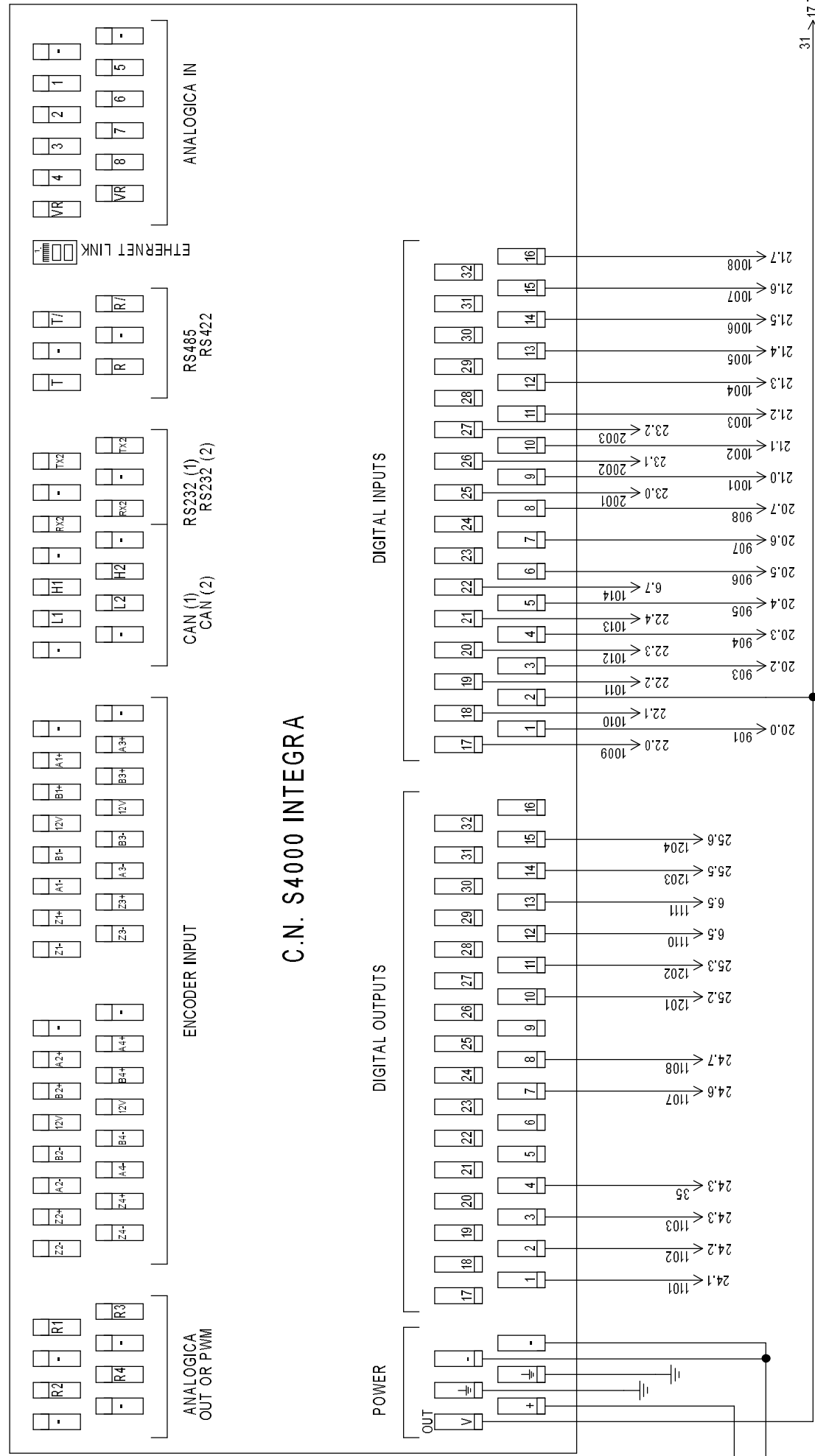

REVISIONE	MODIFICA	PROGETTO: A18-15	FOGLIO 4
		COMMESSA: C4 -CSA	DI 27
		CLIENTE:	
		TITOLO:	
DATA	FIRMA	DIS.: Ellevi product snc	3 < > 5
		DATA: 13/02/2018	

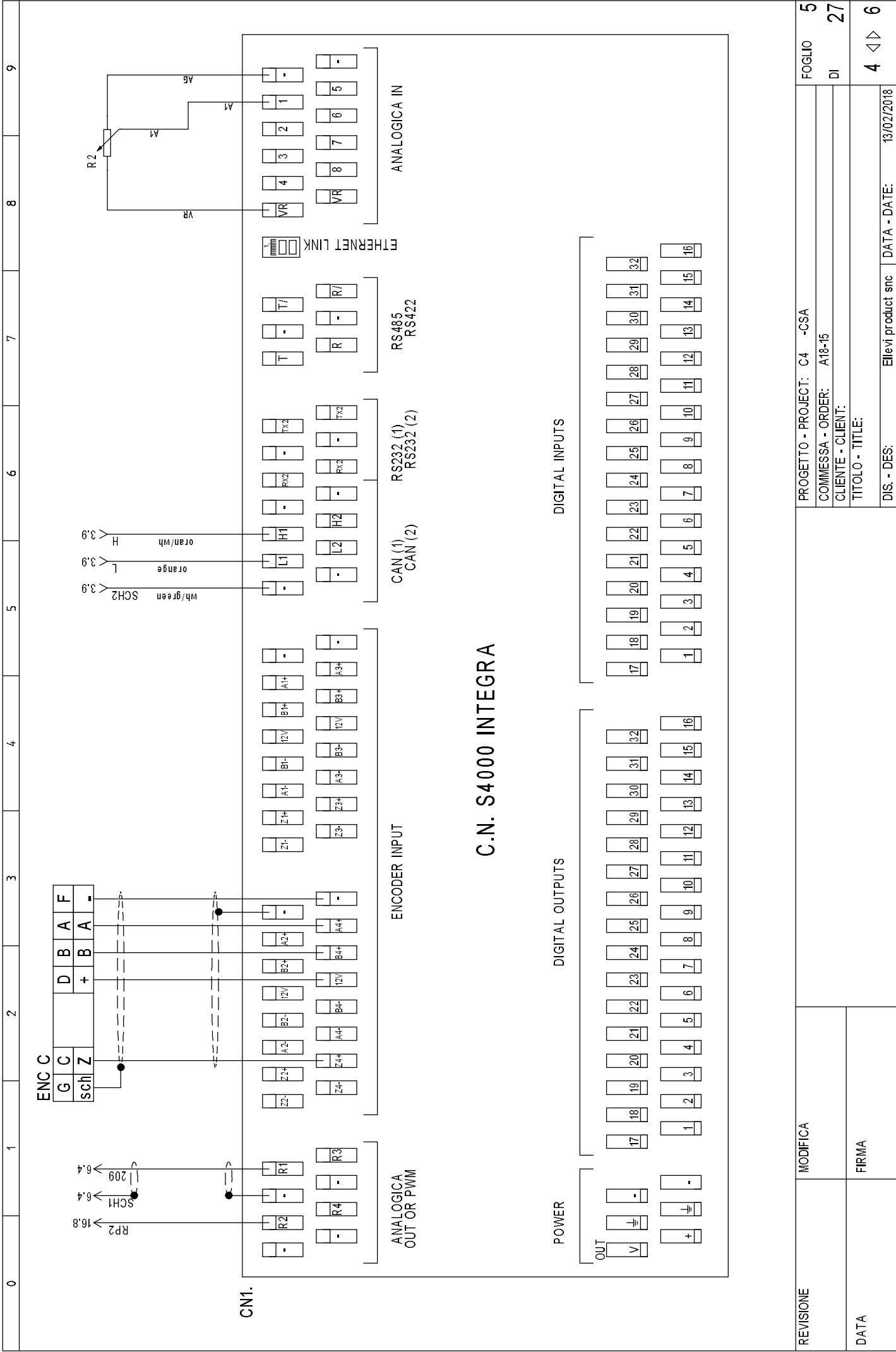

**C.N. S4000 INTEGRA**

REVISIONE	MODIFICA	PROGETTO - PROJECT: C4 -CSA	FOGLIO	5
DATA	FIRMA	COMMESSA - ORDER: A18-15	DI	27
		CLIENTE - CLIENT:		
		TITOLO - TITLE:		
		DIS. - DES: Ellevi product snc	DATA - DATE:	13/02/2018
			4 < >	6

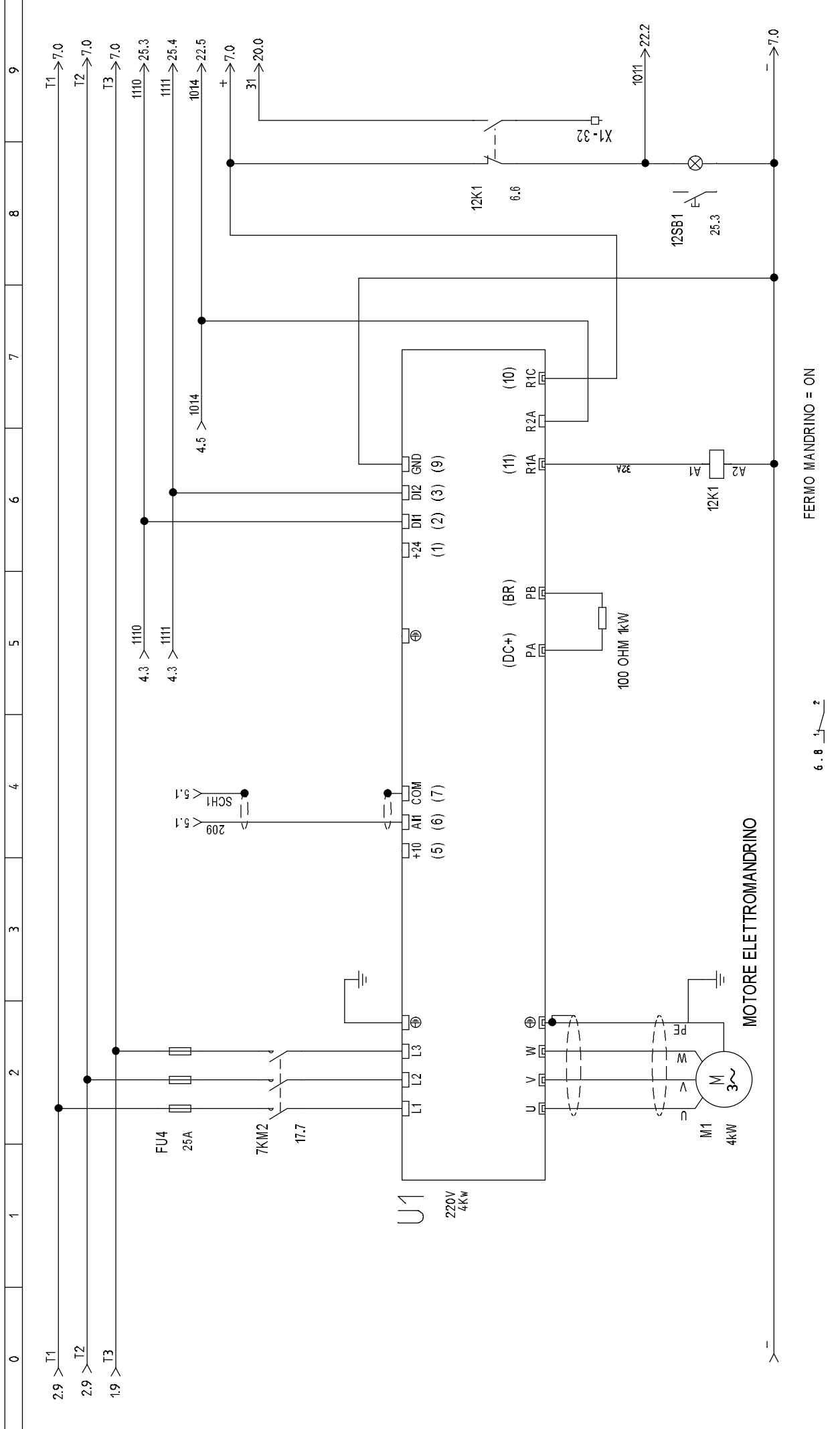

REVISIONE	MODIFICA	PROGETTO - PROJECT: C4 -CSA	FOGLIO 6
DATA	FIRMA	COMMESSA - ORDER: A18-15	DI 27
		CLIENTE - CLIENT: inverter U1	5 < > 7
		TITOLO - TITLE: inverter U1	
		DIS. - DES: Ellevi product snc	13/02/2018

FERMO MANDRINO = ON

6.8 1 2

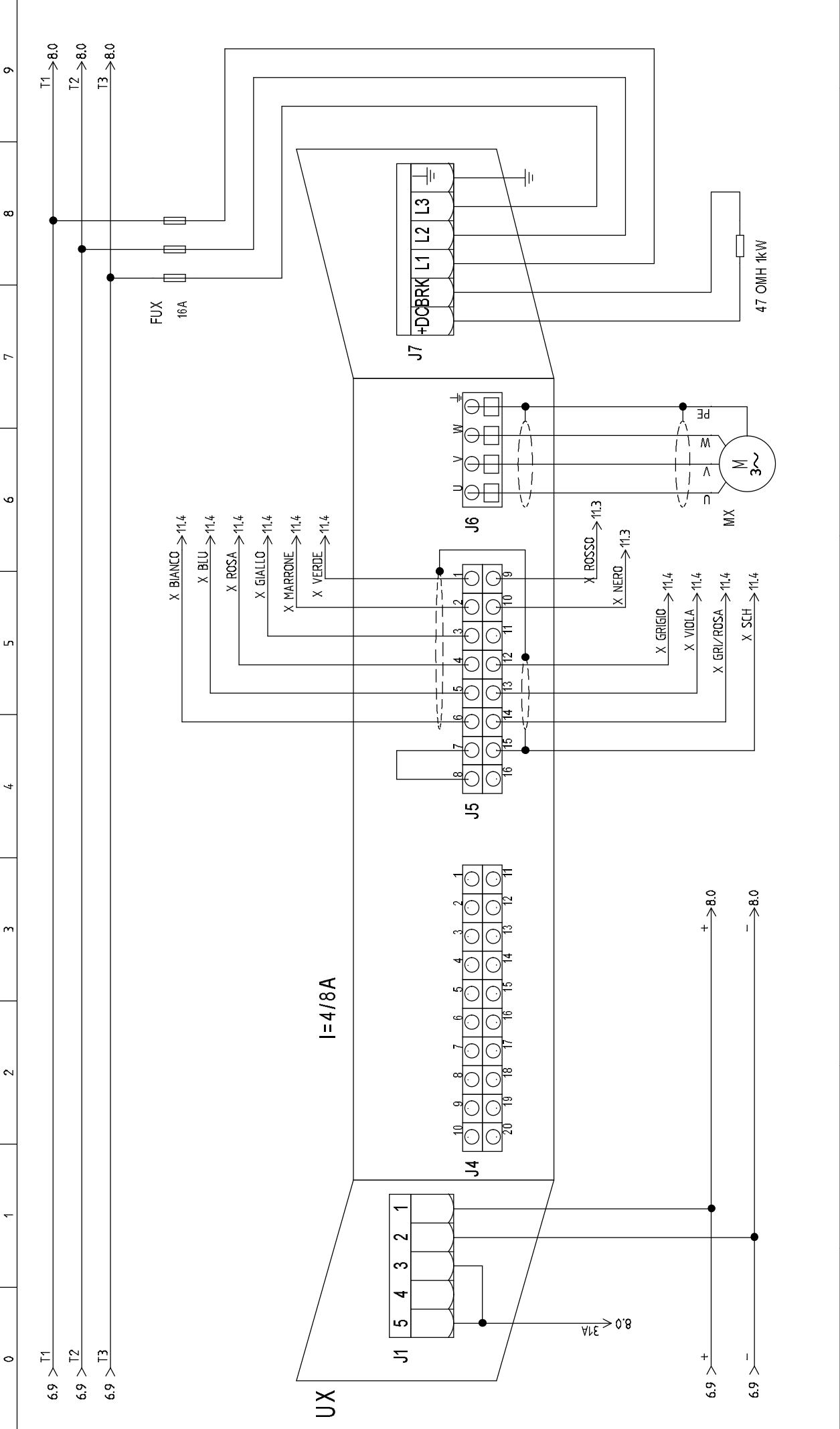

REVISIONE	MODIFICA	PROGETTO - PROJECT: C4 -CSA	FOGLIO	7
DATA	FIRMA	COMMESSA - ORDER: A18-15	DI	27
		CLIENTE - CLIENT: AZION, ASSE X		
		TITOLO - TITLE:		
		DIS. - DES: Ellevi product snc	DATA - DATE:	13/02/2018



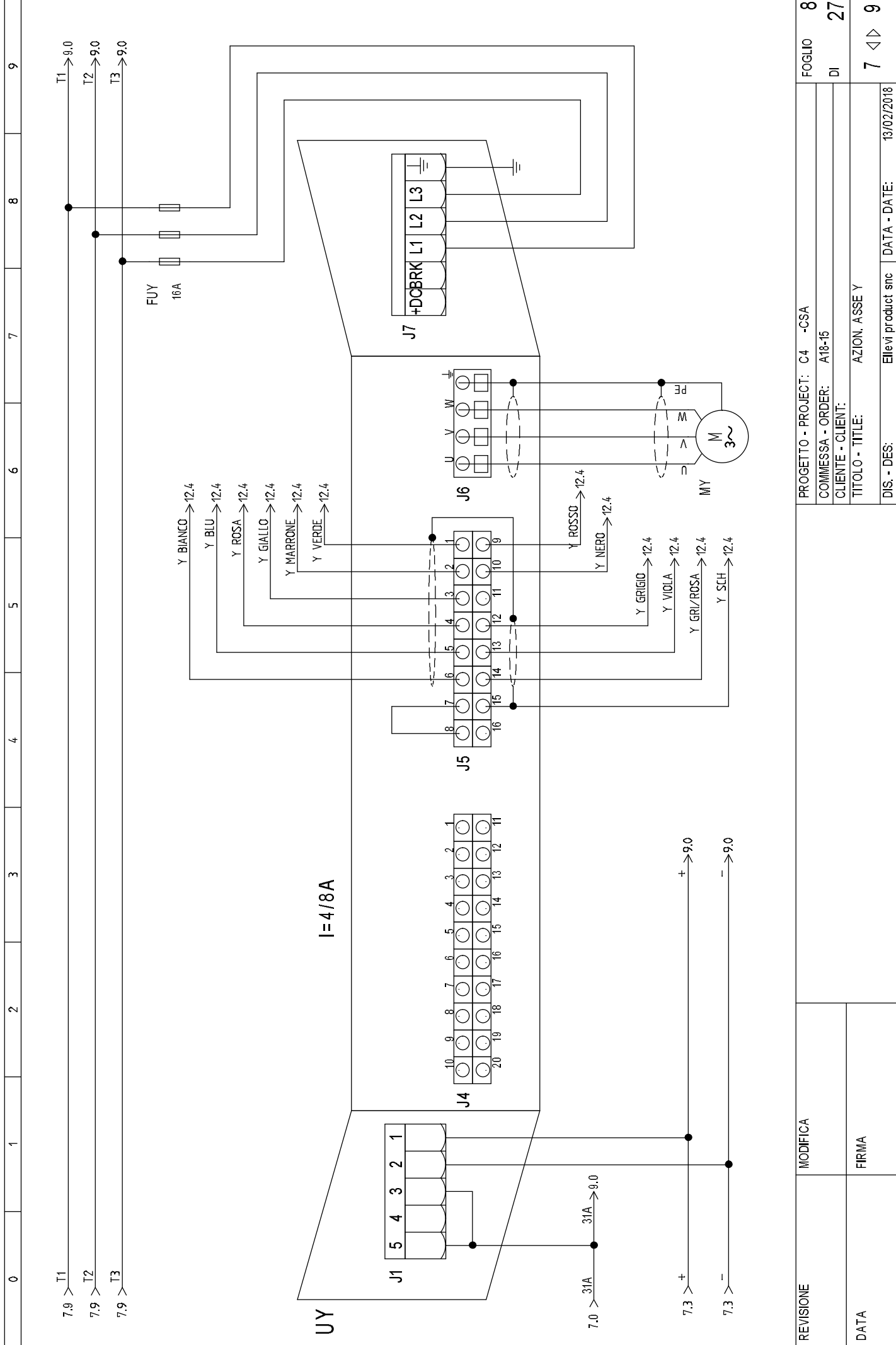

REVISIONE	MODIFICA	FOGLIO	8
DATA	FIRMA	DI	27
		7 < >	9

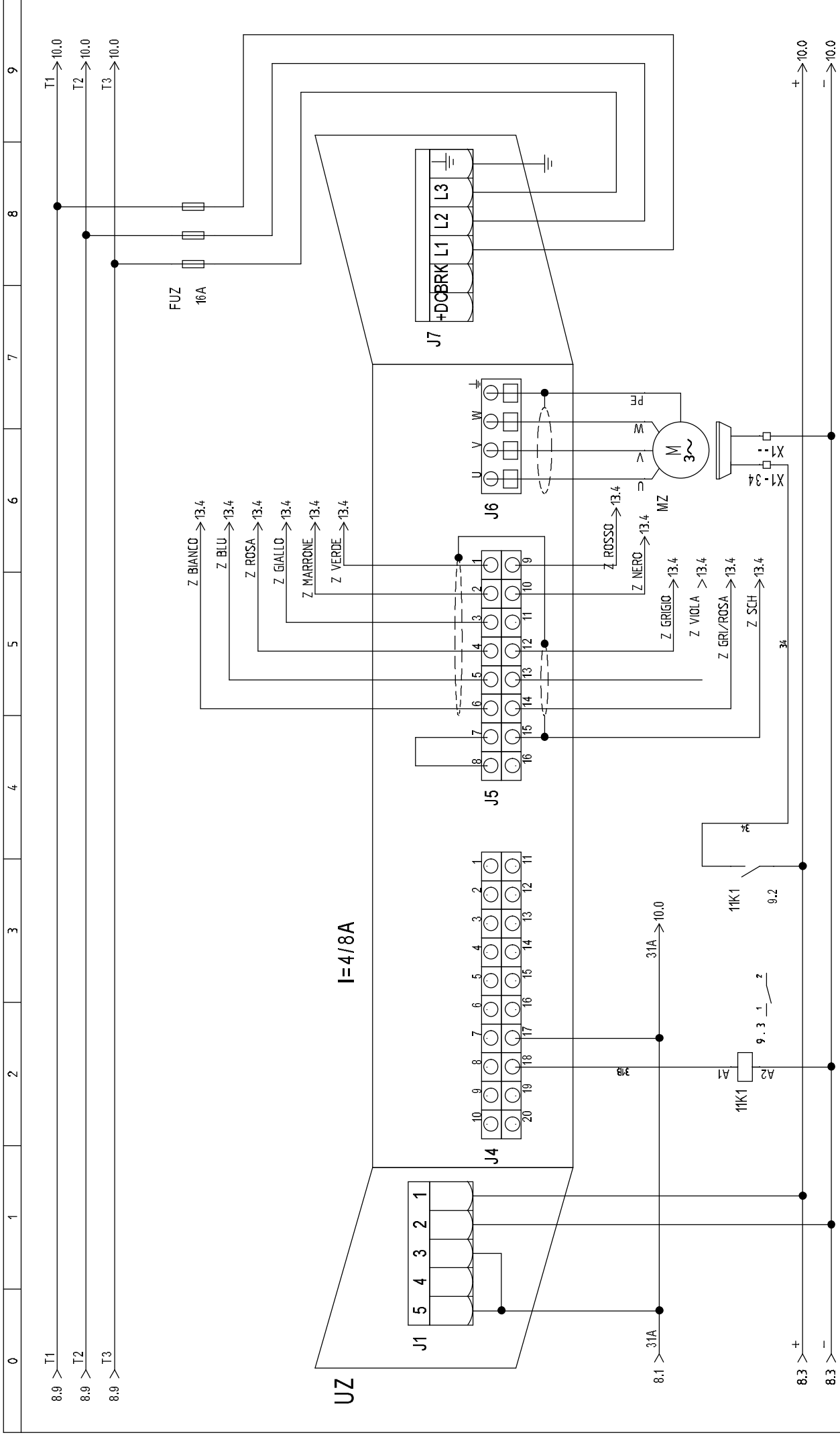

REVISIONE	MODIFICA	PROGETTO - PROJECT: C4 -CSA	FOGLIO 9
DATA	FIRMA	COMMESSA - ORDER: A18-15	DI 27
		CLIENTE - CLIENT: AZION, ASSE Z	
		TITOLO - TITLE:	8 < > 10
		DIS. - DES: Ellevi product snc	13/02/2018
		DATA - DATE:	

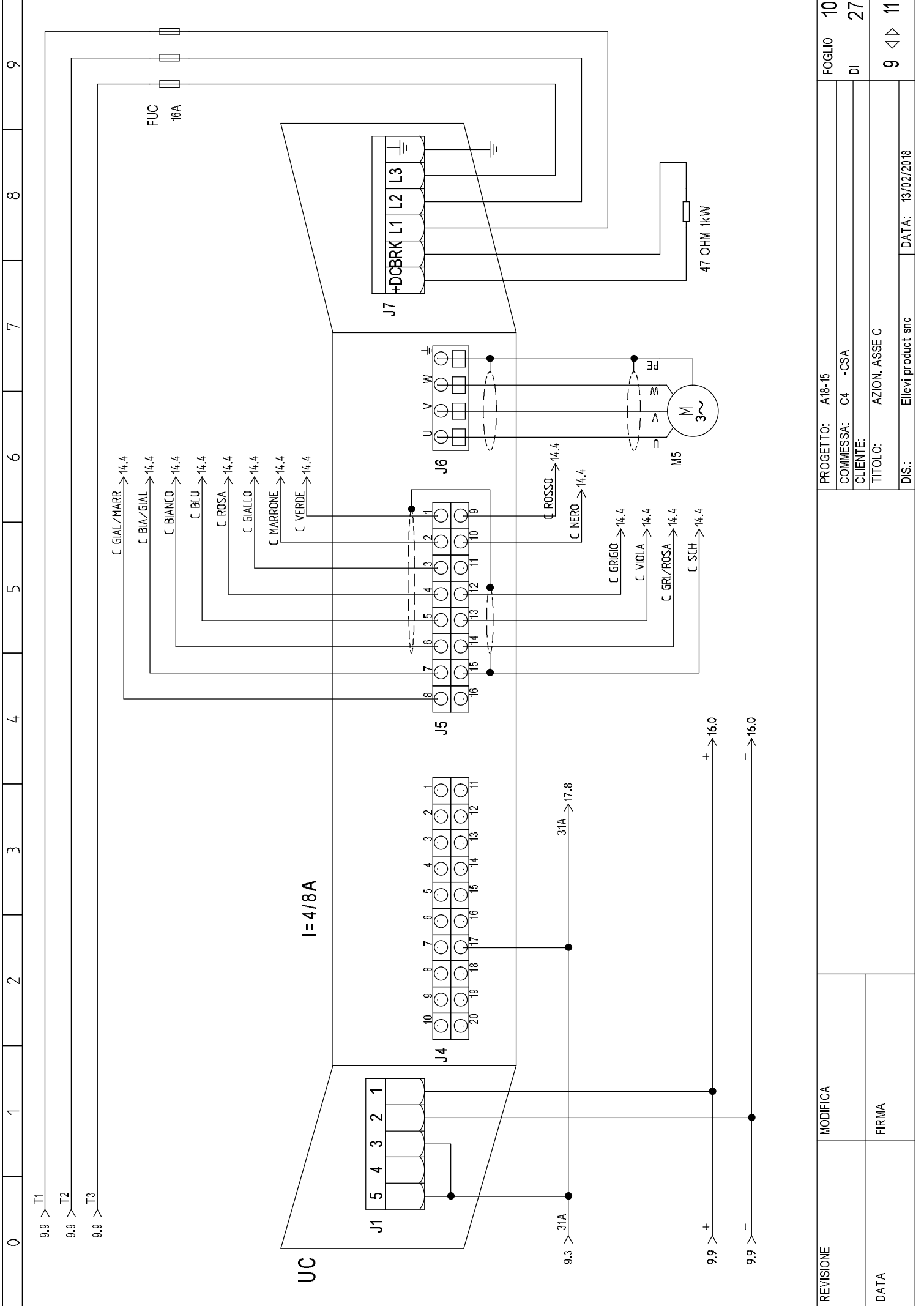

9.9 > T1  
 9.9 > T2  
 9.9 > T3

REVISIONE	MODIFICA	PROGETTO: A18-15	FOGLIO 10
DATA	FIRMA	COMMESSA: C4 -CSA	DI 27
		CLIENTE: AZION, ASSE C	9 < > 11
		DIS.: Ellevi product snc	DATA: 13/02/2018

1	A+
2	A-
3	B+
4	B-
5	Z+
6	Z-
7	PTC
8	PTC
9	+Vdc
10	GND
11	N.C.
12	HA+
13	HB+
14	HC+
15	SCH
16	

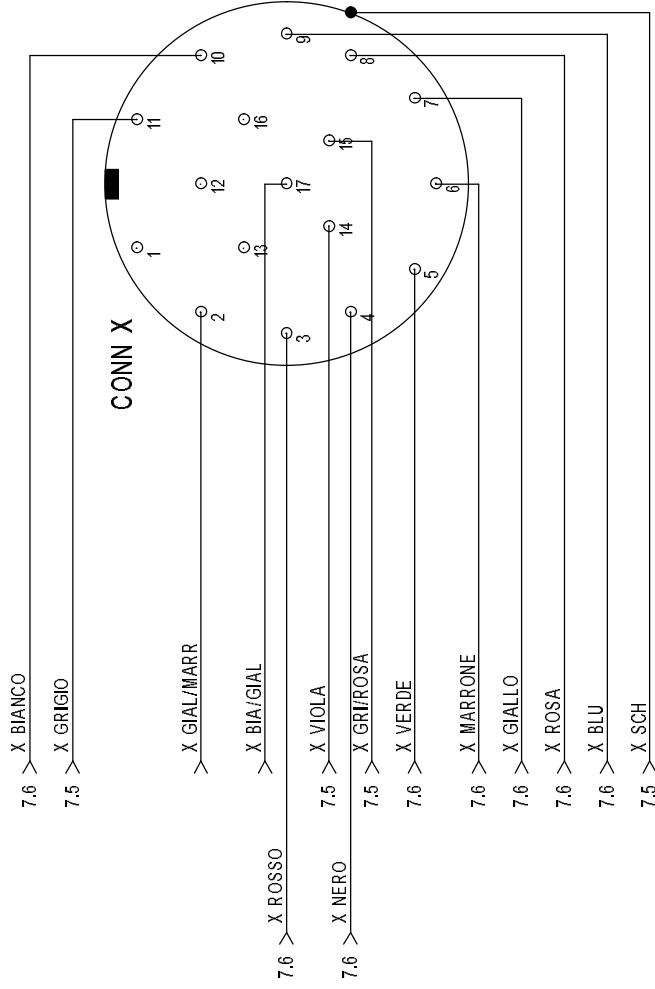

REVISIONE	MODIFICA	PROGETTO: A18-15	FOGLIO 11
		COMMESSA: C4 -CSA	DI 27
		CLIENTE:	
		TITOLO: CONN. ASSE X	
DATA	FIRMA	DIS.: Ellevi product snc	10 < > 12
		DATA: 13/02/2018	

1	A+
2	A-
3	B+
4	B-
5	Z+
6	Z-
7	PTC
8	PTC
9	+Vdc
10	GND
11	N.C.
12	HA+
13	HB+
14	HC+
15	SCH
16	

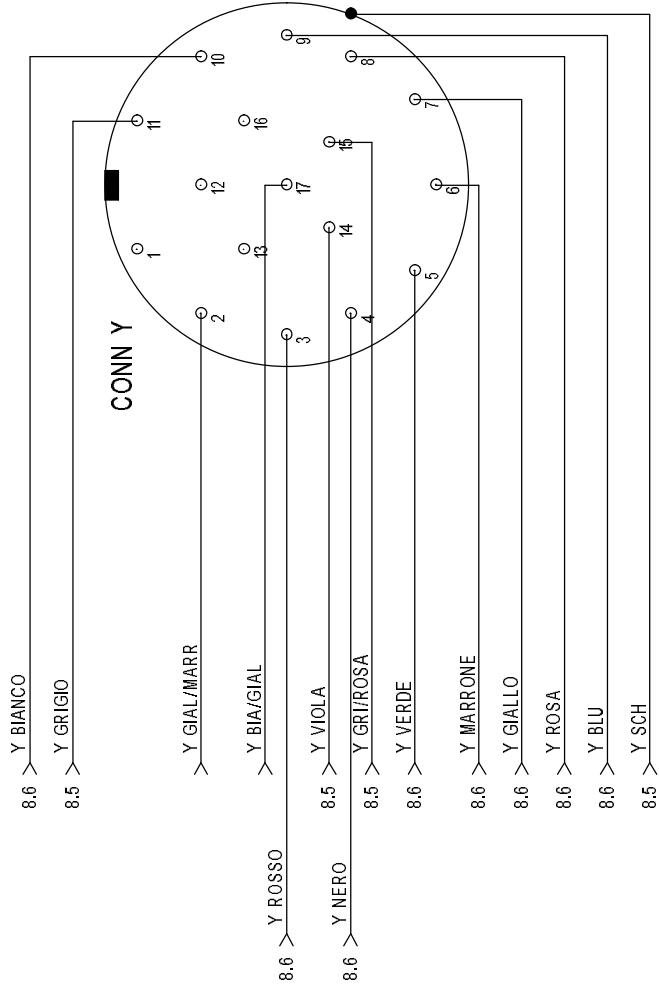

REVISIONE	MODIFICA	PROGETTO: A18-15	FOGLIO 12
		COMMESSA: C4 -CSA	DI 27
		CLIENTE:	
DATA	FIRMA	TITOLO: CONN. ASSE Y	11 < > 13
		DIS.: Ellevi product snc	DATA: 13/02/2018

1	A+
2	A-
3	B+
4	B-
5	Z+
6	Z-
7	PTC
8	PTC
9	+Vdc
10	GND
11	N.C.
12	HA+
13	HB+
14	HC+
15	SCH
16	

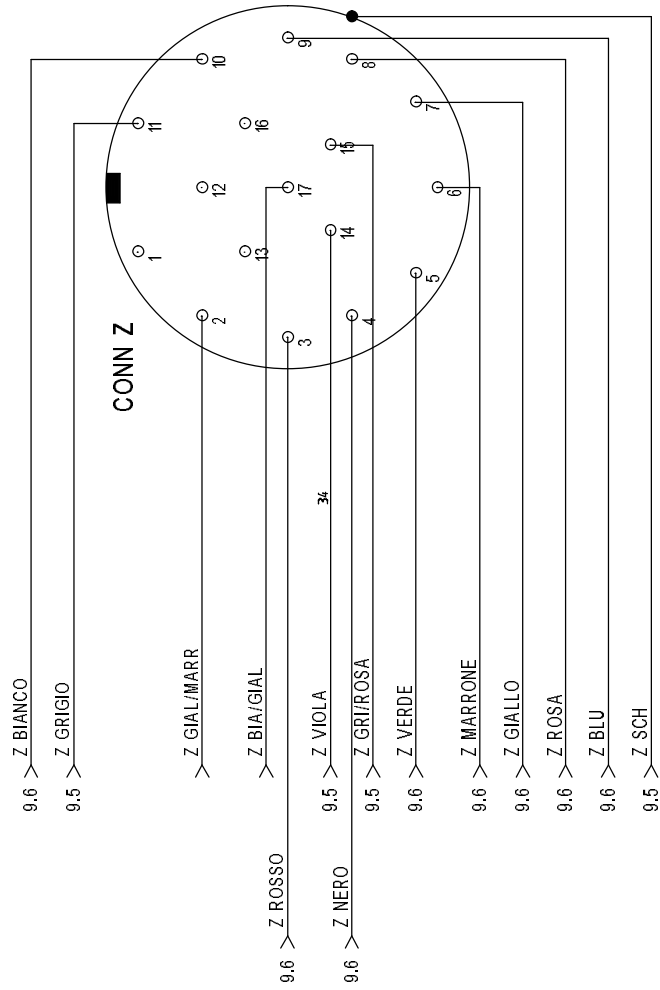

REVISIONE	MODIFICA	PROGETTO: A18-15	FOGLIO 13
		COMMESSA: C4 -CSA	DI 27
		CLIENTE:	
		TITOLO: CONN. ASSE Z	
DATA	FIRMA	DIS.: Ellevi product snc	12 < > 14
		DATA: 13/02/2018	

1	A+
2	A-
3	B+
4	B-
5	Z+
6	Z-
7	PTC
8	PTC
9	+Vdc
10	GND
11	N.C.
12	HA+
13	HB+
14	HC+
15	SCH
16	

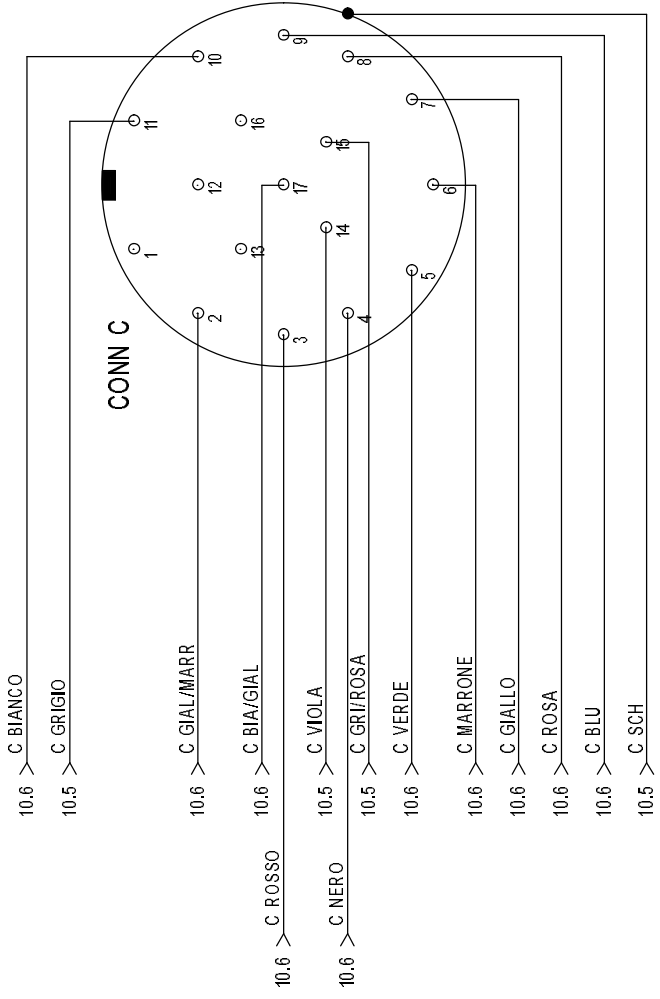

REVISIONE	MODIFICA	PROGETTO - PROJECT: C4 -CSA	FOGLIO 14
		COMMESSA - ORDER: A18-15	DI 27
		CLIENTE - CLIENT: CONN, ASSE C	
		TITOLO - TITLE: CONN, ASSE C	
DATA	FIRMA	DIS. - DES: Ellevi product snc	13 < > 16
		DATA - DATE: 13/02/2018	

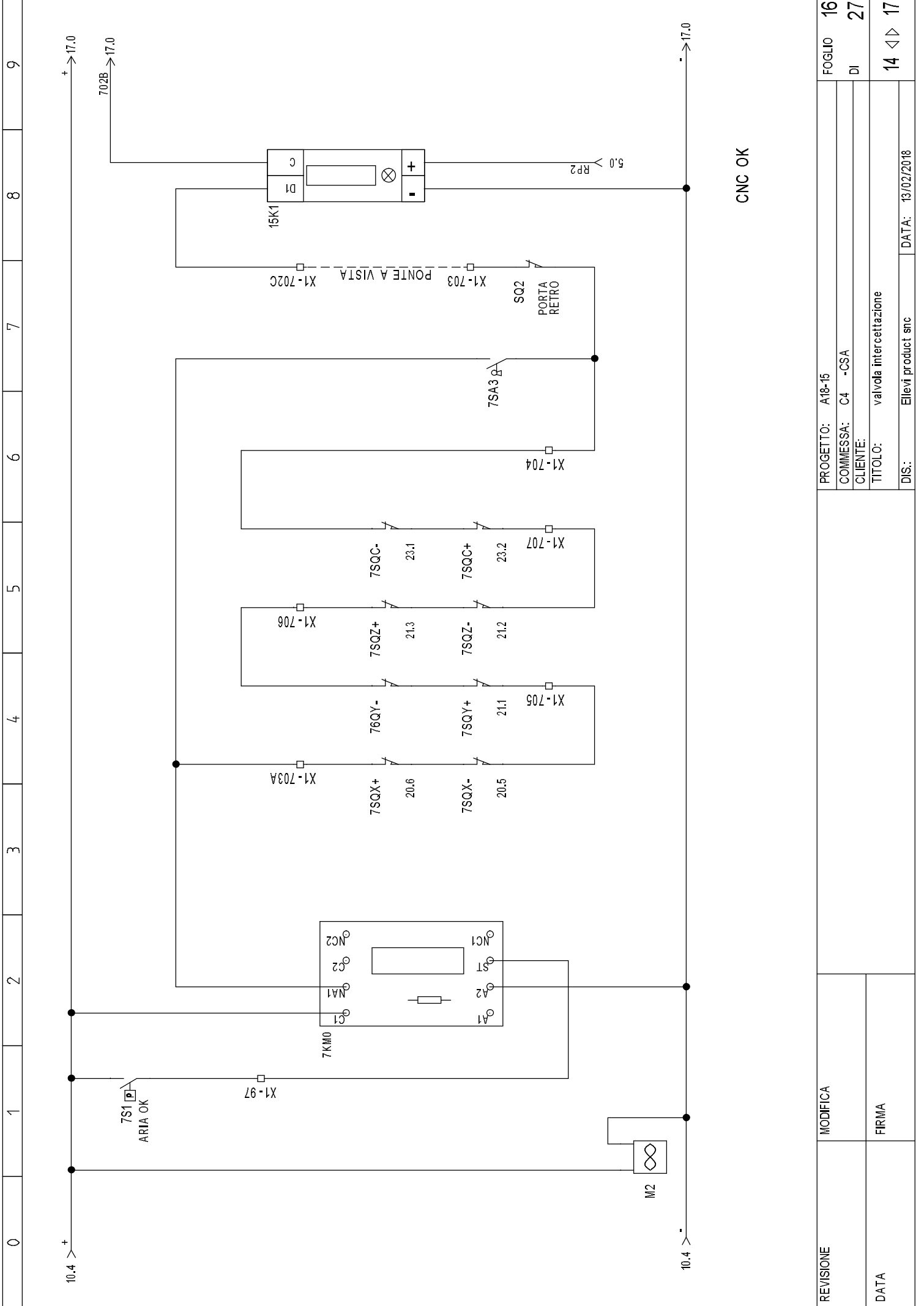

CNC OK

REVISIONE	MODIFICA	PROGETTO: A18-15	FOGLIO 16
		COMMESSA: C4 -CSA	DI 27
		CLIENTE:	
		TITOLO: valvola intercettazione	14 < > 17
DATA	FIRMA	DIS: Ellevi product snc	DATA: 13/02/2018



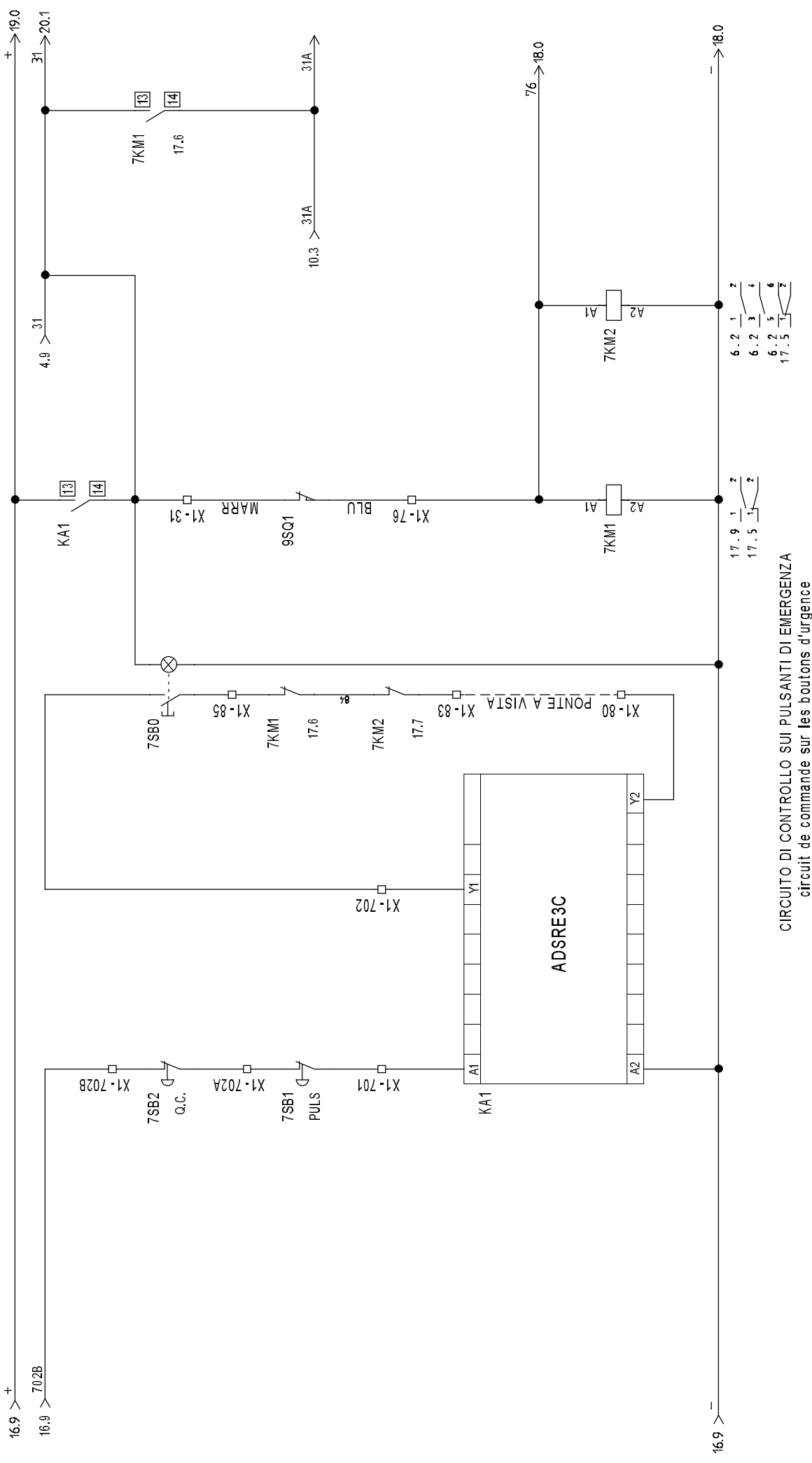

CIRCUITO DI CONTROLLO SUI PULSANTI DI EMERGENZA  
circuit de commande sur les boutons d'urgence

REVISIONE	MODIFICA	PROGETTO - PROJECT: C4 -CSA	FOGLIO 17
		COMMESSA - ORDER: A18-15	DI 27
DATA	FIRMA	CLIENTE - CLIENT: controllo su emergenza	16 < > 18
		DIS. - DES: Ellevi product snc	DATA - DATE: 13/02/2018

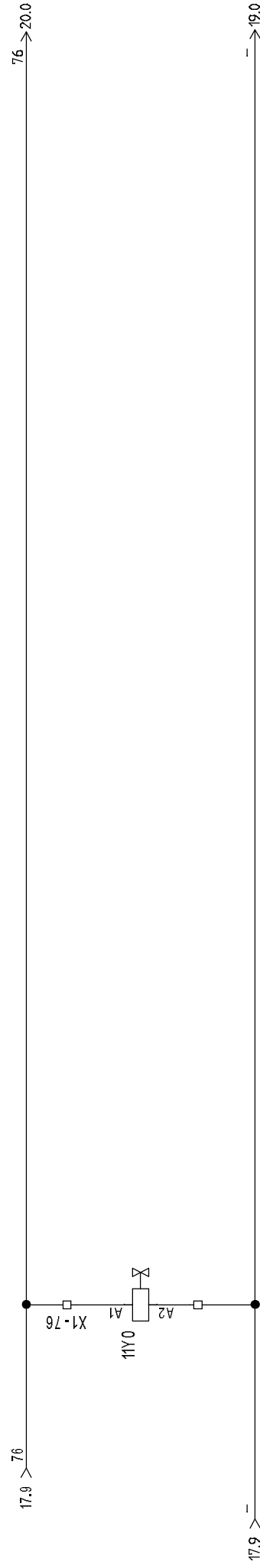

VALVOLA DI INTERCETTAZIONE  
ARIA SU OUT 1/8

REVISIONE	MODIFICA	PROGETTO - PROJECT: C4 -CSA	FOGLIO 18
		COMMESSA - ORDER: A18-15	DI 27
DATA	FIRMA	CLIENTE - CLIENT: intercettazione	17 < > 19
		DIS. - DES: Ellevi product snc	13/02/2018
		DATA - DATE:	

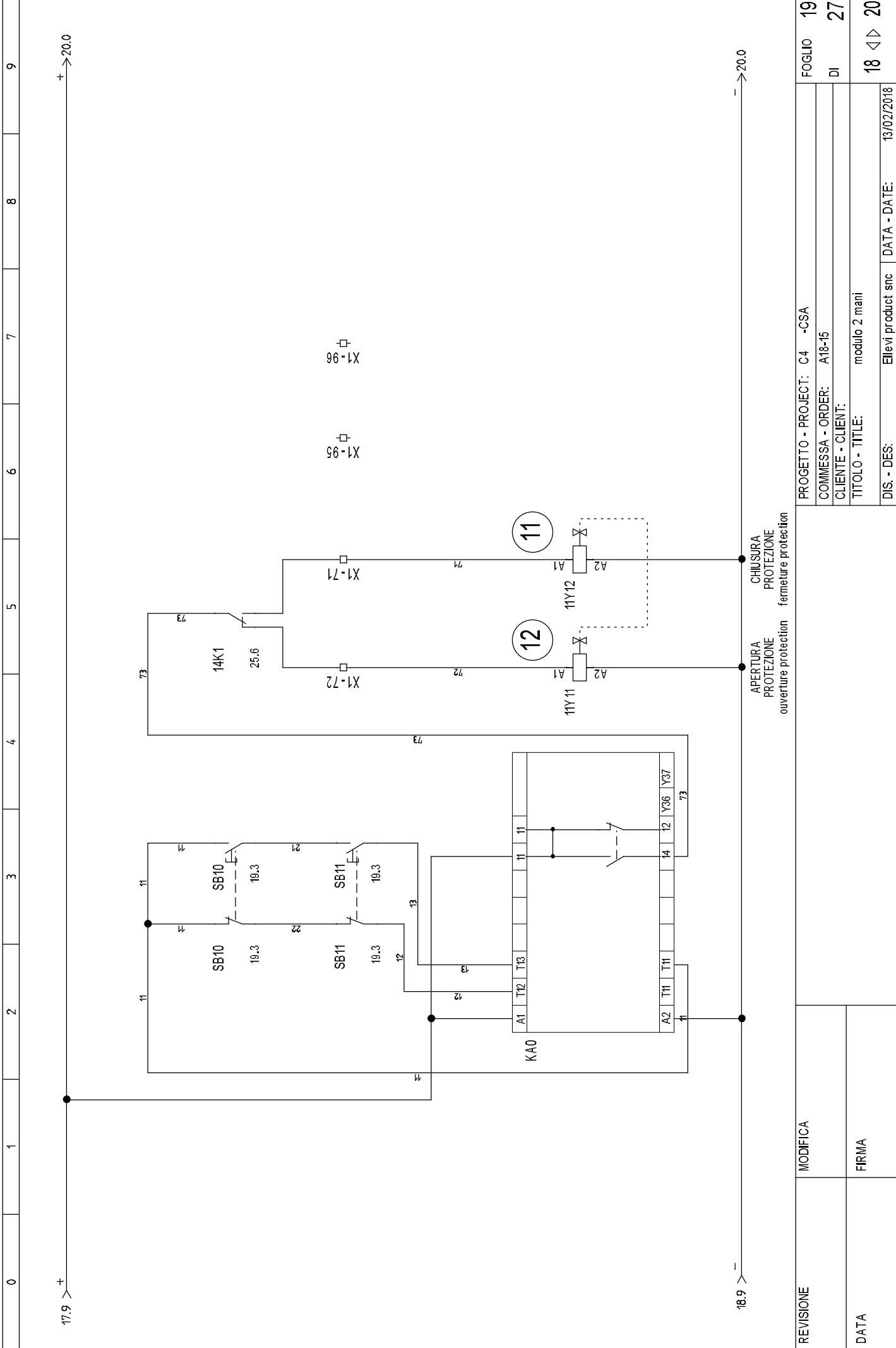

REVISIONE	MODIFICA	PROGETTO - PROJECT: C4 - CSA	FOGLIO 19
DATA	FIRMA	COMMESSA - ORDER: A18-15	DI 27
		CLIENTE - CLIENT: modulo 2 mani	18 < > 20
		TITOLO - TITLE: Ellevi product snc	13/02/2018
		DIS - DES: DATA - DATE:	

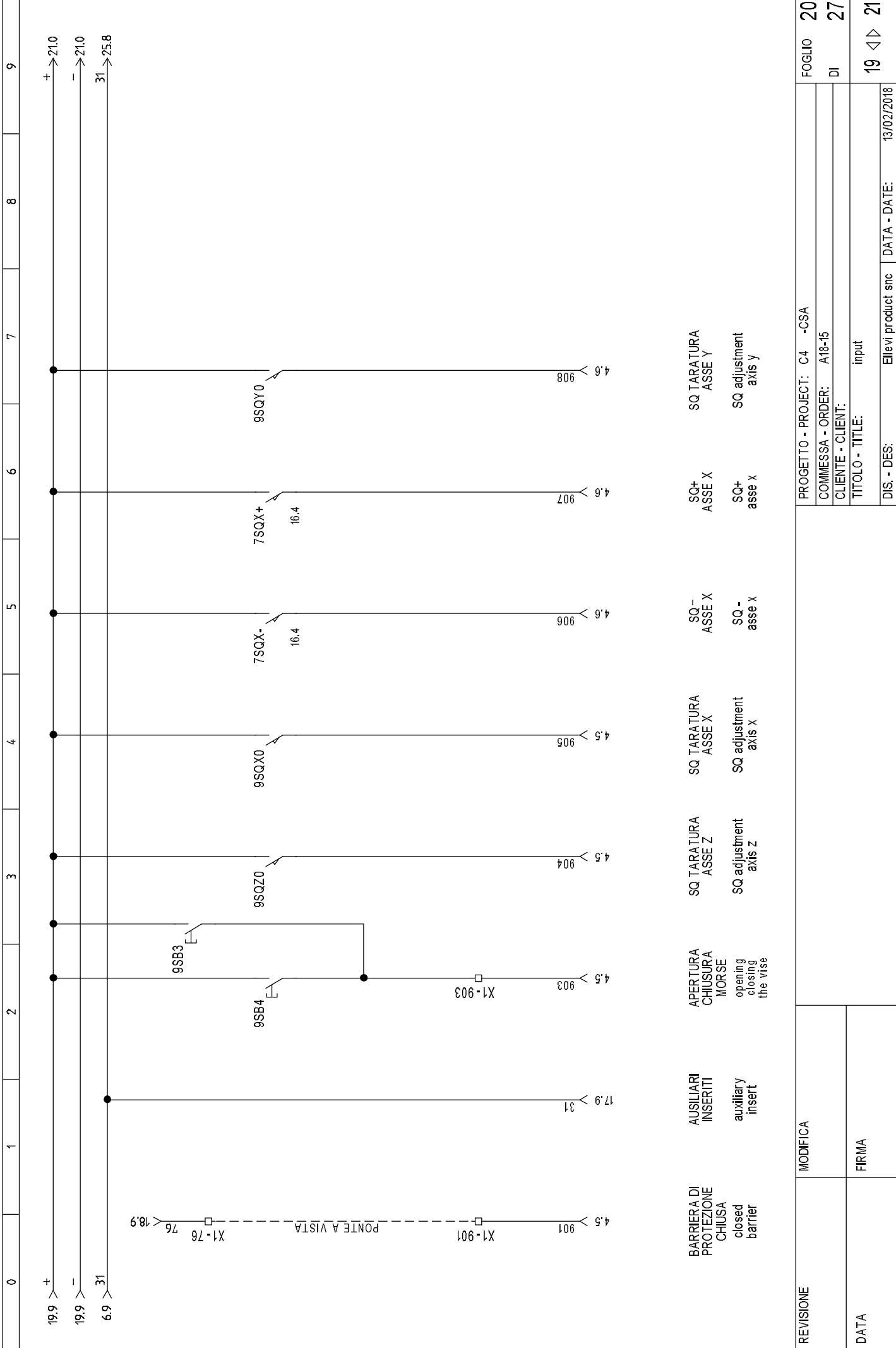

REVISIONE	MODIFICA	PROGETTO - PROJECT: C4 -CSA	FOGLIO 20
DATA	FIRMA	COMMESSA - ORDER: A18-15	DI 27
		CLIENTE - CLIENT:	
		TITOLO - TITLE: input	19 < > 21
		DIS. - DES: Ellevi product snc	13/02/2018

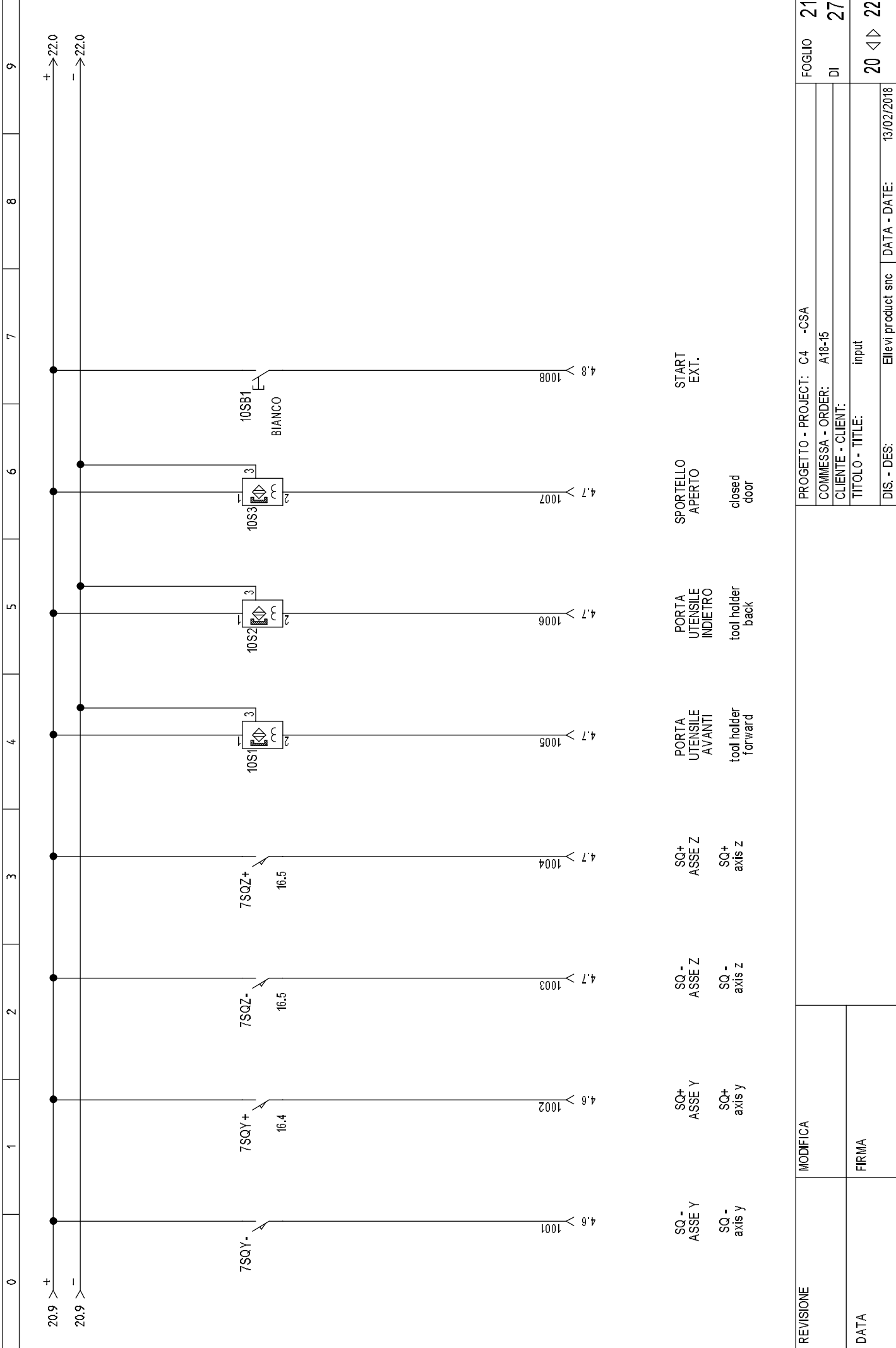

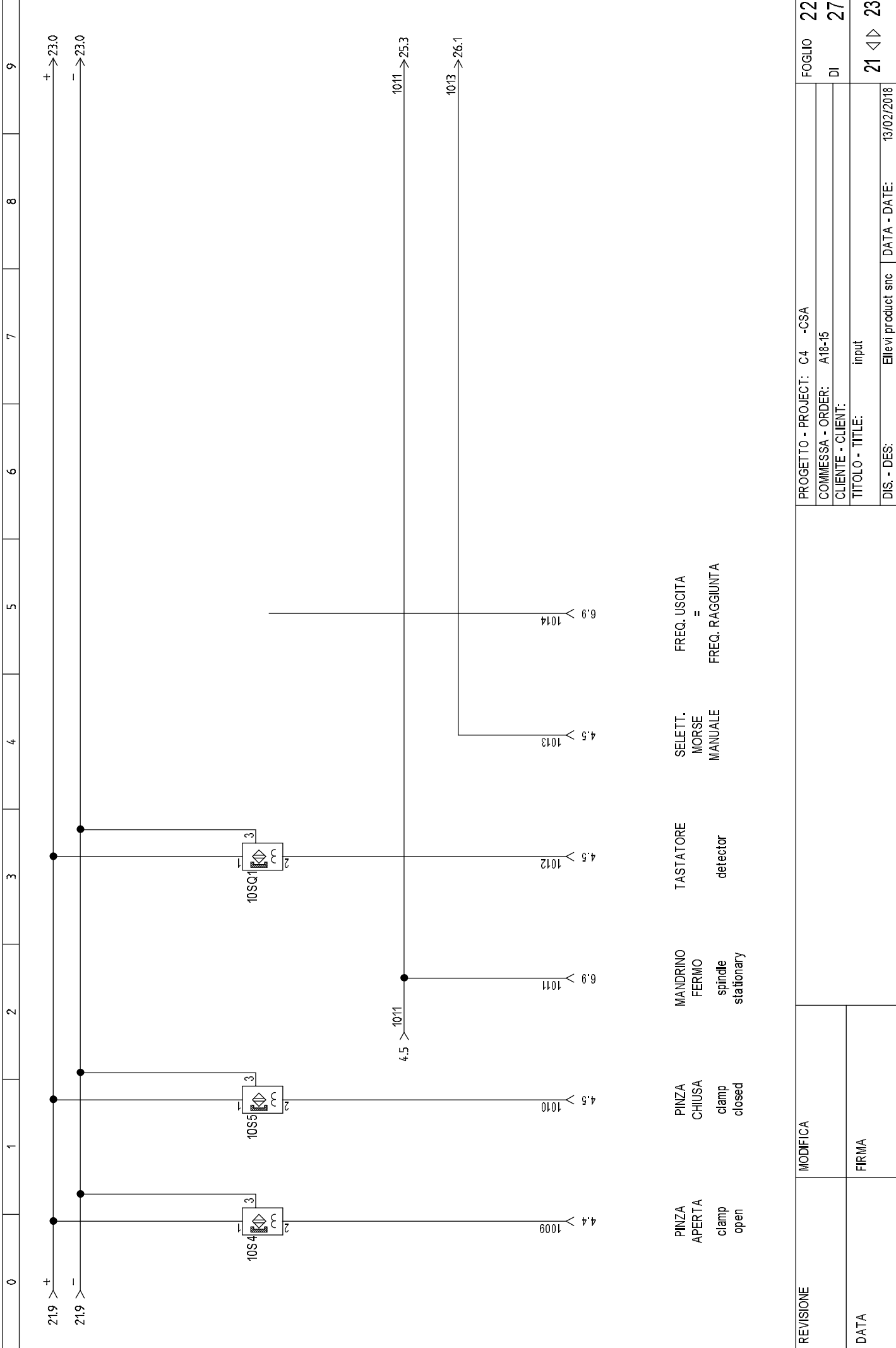

REVISIONE	MODIFICA	PROGETTO - PROJECT: C4 -CSA	FOGLIO 22
DATA	FIRMA	COMMESSA - ORDER: A18-15	DI 27
		CLIENTE - CLIENTE:	
		TITOLO - TITLE: input	
		DIS. - DES: Ellevi product snc	21 < > 23
		DATA - DATE: 13/02/2018	

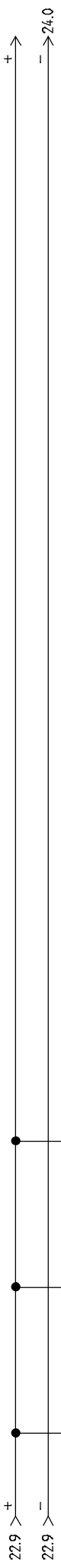

ASSE C

REVISIONE	MODIFICA	PROGETTO: A18-15	FOGLIO 23
		COMMESSA: C4 -CSA	DI 27
		CLIENTE:	
		TITOLO: libero	22 < > 24
DATA	FIRMA	DIS.: Ellevi product snc	DATA: 13/02/2018

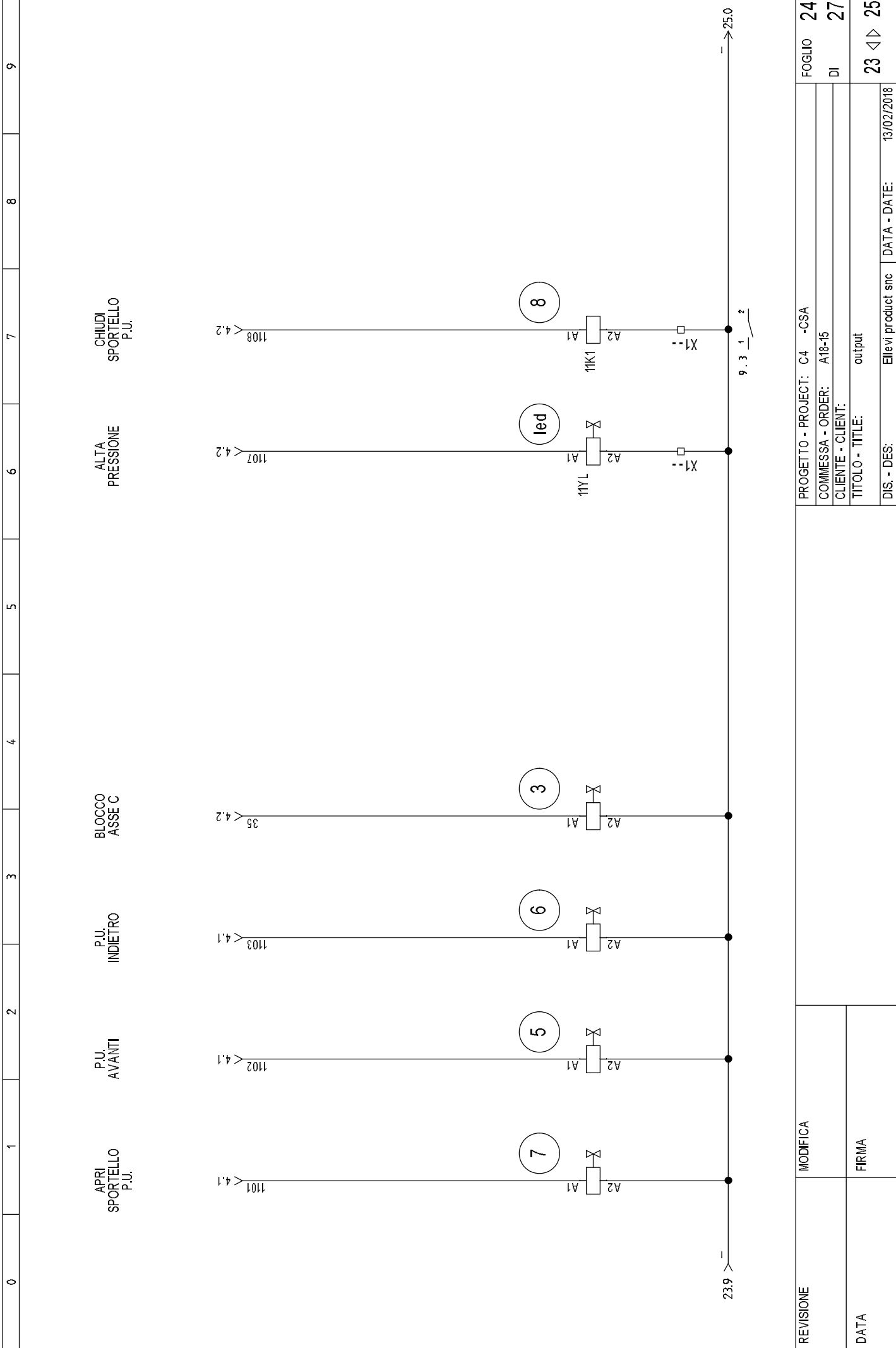

REVISIONE	MODIFICA	PROGETTO - PROJECT: C4 -CSA	FOGLIO 24
DATA	FIRMA	COMMESSA - ORDER: A18-15	DI 27
		CLIENTE - CLIENT: output	
		TITOLO - TITLE: output	
		DIS. - DES: Ellevi product snc	
		DATA - DATE: 13/02/2018	
			23 < > 25



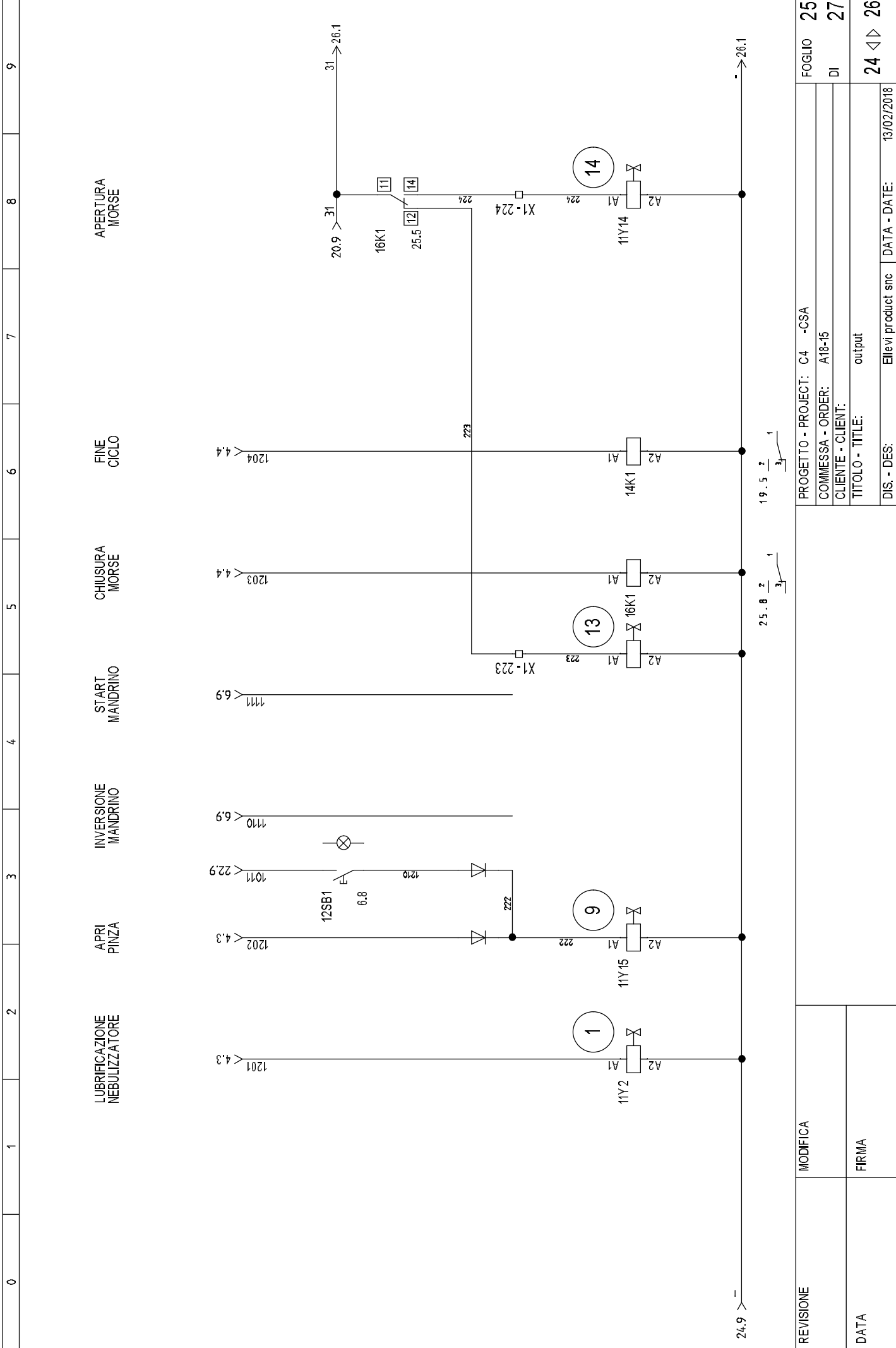

LUBRIFICAZIONE  
NEBULIZZATORE

APRI  
PINZA

INVERSIONE  
MANDRINO

START  
MANDRINO

CHIUSURA  
MORSE

FINE  
CICLO

APERTURA  
MORSE

REVISIONE	MODIFICA	PROGETTO - PROJECT: C4 -CSA	FOGLIO 25
		COMMESSA - ORDER: A18-15	DI 27
		CLIENTE - CLIENT: output	
		TITOLO - TITLE: output	
DATA	FIRMA	DIS. - DES: Ellevi product snc	24 < > 26
		DATA - DATE: 13/02/2018	

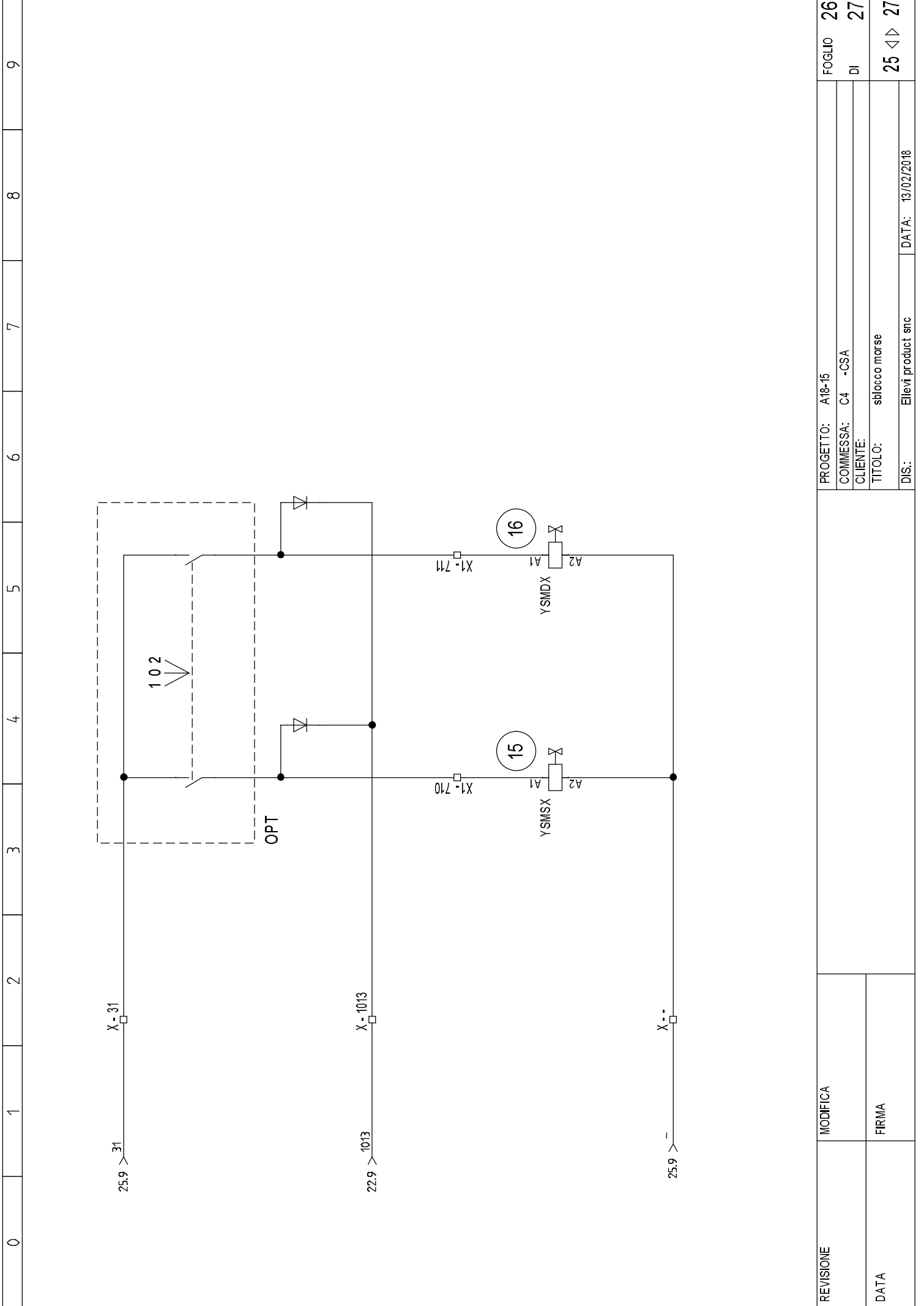

REVISIONE	MODIFICA	PROGETTO: A18-15	FOGLIO 26
DATA	FIRMA	COMMESSA: C4 -CSA	DI 27
		CLIENTE: sblocco morse	25 < > 27
		DIS.: Ellevi product snc	DATA: 13/02/2018

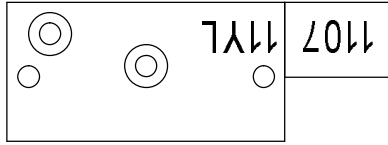



ALTA  
PRESSIONE



VALVOLA  
INTERCETTAZIONE

1	BIANCO	1201
2	MARRONE	
3	VERDE	35
4	GIALLO	
5	GRIGIO	1102
6	ROSA	1103
7	BLU	1101
8	ROSSO	1108
9	NERO	222
10	VIOLA	
11	GRI/ROSA	71
12	ROSSO/BLU	72
13	BIA/VER	223
14	MARR/VER	224
15	BIA/GIA	710
16	GIA/MARR	711
17	BIA/GRI	
18	GRI/MARR	
19	BIA/ROSA	
20	ROSA/MARR	
21	BIA/BLU	
22	MARR/BLU	
23	BIA/ROSSO	
24	MARR/ROSSO	-
25	BIA/NERO	-

REVISIONE	MODIFICA	PROGETTO - PROJECT: C4 -CSA	FOGLIO 27
		COMMESSA - ORDER: A18-15	DI 27
		CLIENTE - CLIENT:	
		TITOLO - TITLE: gruppo elettrovalvole	
DATA	FIRMA	DIS. - DES: Ellevi product snc	26 < > 28
		DATA - DATE: 13/02/2018	

0	1	2	3	4	5	6	7	8	9		
<b>PARAMETRI INVERTER DC1- MANDRINO C4</b>											
<b>PARAMETRI DI FABBRICA:</b> <b>PREMERE CONTEMPORANEAMENTE I PULSANTI  +  +  PER 2 SECONDI</b>											
P03 = 3" (accelerazione) P04 = 4.5" (decelerazione) P05 = 0 (abilitazione decelerazione) P08 = 16A P09 = 500.0 Hz (frequenza motore) P01 = 500.0 (frequenza massima) P14 = 101 P15 = 5 P18 = 4 (frequenza di uscita > P19) P19 = 1 (Hz) P33 = 0 (tempo di frenatura all'avvio disattivato) P34 = 1 (attivazione choper di frenatura con resistenza di frenatura di prot. contro sovraccarichi) P25 = 2 (freq.uscita=freq. raggiunta) su OUT D01=1											
REVISIONE	MODIFICA		PROGETTO - PROJECT: C4 -CSA COMMESSA - ORDER: A18-15 CLIENTE - CLIENT: parametri inverter TITOLO - TITLE: parametri inverter DIS. - DES: Ellevi product snc DATA - DATE: 13/02/2018							FOGLIO	28
DATA	FIRMA									DI	27
									27	< >	

# **PNEUMATIC DIAGRAM**

**C4 PLUS**



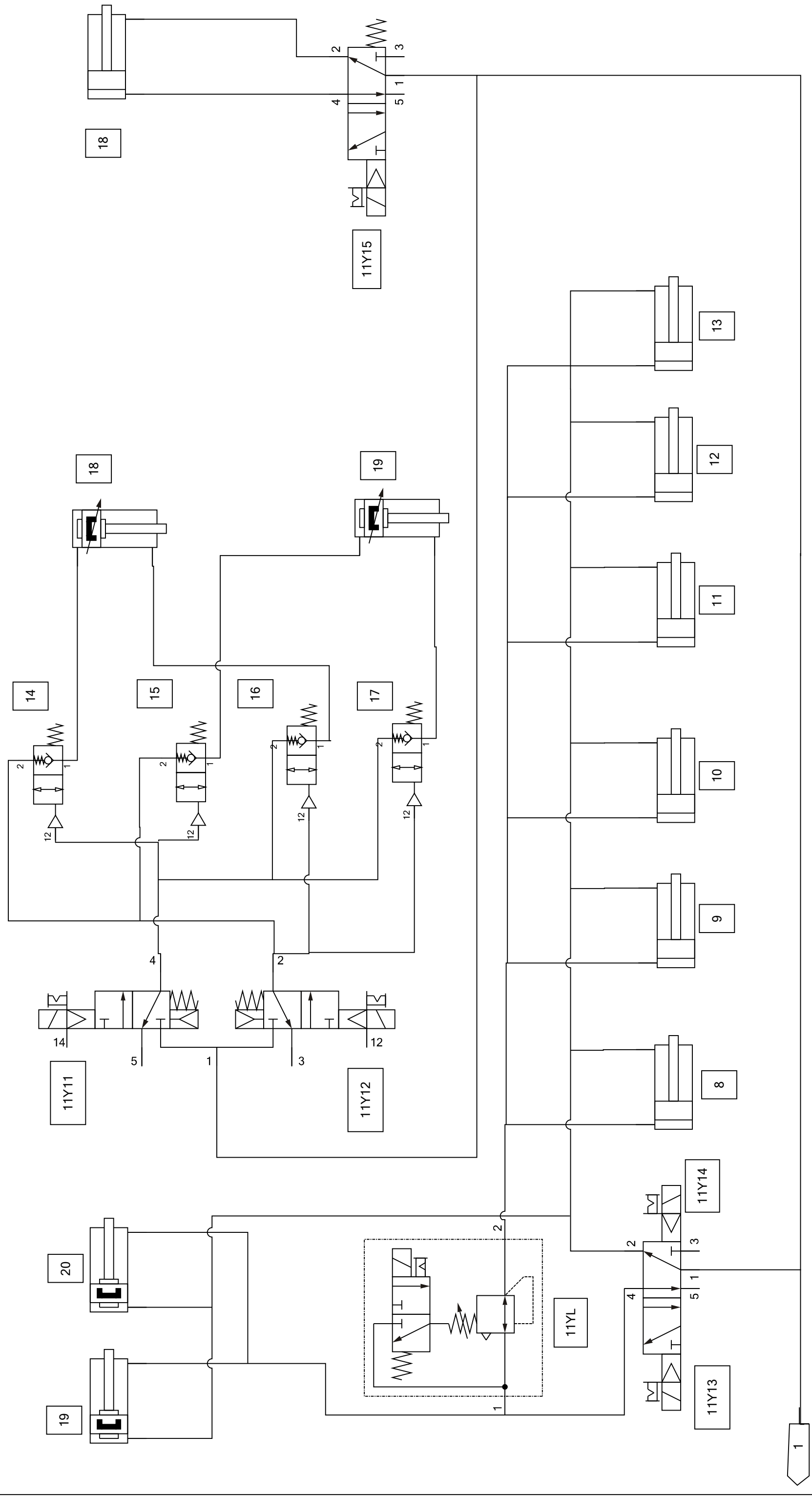

IM4	DISEGNATO	CONTROLLAT.
IM3	DATA	29-01-18
IM2	FIRMA	29-01-18
IM1	DISEGNO ESEGUITO CON SISTEMA CAD, NON SONO AMMESSE MODIFICHE MANUALI	
I.M.	DESCRIZIONE MODIFICA	DATA
	GRUPPO	I.M.
	DENOMINAZIONE	SCALA
		N. DISEGNO
		ATLANTIS C4 PLUS

	A	B	C	D	E	F
1						
2	<b>Code</b>	<b>Page</b>		<b>Part. No.</b>	<b>Description</b>	<b>Function</b>
3	11Y0	1		BT-71740	Isolation valve	
4	2	1		CA-71011+CA-70042+CA-70043	Filter, lubricator and air pressure regulator	Air filtering, lubrication and pressure regulation
5	3	1		CH-72021	Microdrop lubrication	Tool lubrication
6	11Y2	1		BT-71738	3/2 monostable solenoid valve	Tool lubrication
7	11Y15	1		BT-71738	3/2 monostable solenoid valve	Open/close tool clamp inside spindle
8	4	1			Clamp/Unclamp tool cylinder	Intgrated inside spindle
9	11Y3-11Y4	1		BT-71550	5/2 bistable solenoid valve	Open/close tool changer
10	5-6	1		CN-71153	Cylinder Ø40-300	Open/close tool changer
11	1101	1		BT-71082	5/2 monostable solenoid valve	Open/close tool changer cover
12	7	1		CN-71257	Cylinder Ø32-150	Open/close tool changer cover
13	11Y13-11Y14	2		BT-71550	5/2 bistable solenoid valve	Open/close clamps
14	11YL	2		BR-71052	2 pressions solenoid valve	High/low pressure for clamps
15	8			CN-70497	Comapct cylinder Ø40-30	Clamp cylinder
16	9	2		CN-70497	Comapct cylinder Ø40-30	Clamp cylinder
17	10	2		CN-70497	Comapct cylinder Ø40-30	Clamp cylinder
18	11	2		CN-70497	Comapct cylinder Ø40-30	Clamp cylinder
19	12	2		CN-70497	Comapct cylinder Ø40-30	Clamp cylinder
20	13	2		CN-70497	Comapct cylinder Ø40-30	Clamp cylinder
21	11Y11-11Y12	2		BT-71738	Solenoid valve 2x3/2 NC	Open/close frontal cover
22	14-15-16-17	2		BT-70050	Check valve	
23	18-19	2		CN-71299	Clamp Ø40-750	Open/close frontal cover
24	11Y1	2		BT-71082	5/2 bistable solenoid valve	Lock/unlock table rotation (C axis)
25	18	2		CN-70289	Compact special cylinder Ø80-5	Lock/unlock table rotation (C axis)
26	19-20	2		CN-71179	Verin Ø20-50	Ouverture / fermeture référence de la pièce
27						
28						TIPO MACCHINA: C4 PLUS
29						DATA: 29/01/2018 MODIFICATO: 29/01/2018
30						TITOLO: DISTINTA MATERIALE + FUNZIONI
31						